

CONTAINER TILTERS

for Every Application



- Improve worker productivity and safety
- Eliminate bending, stretching, & reaching

SOUTHWORTH
We'll Show You How

HANDLE PARTS IN CONTAINERS OR TOTES WITHOUT BENDING, LIFTING OR REACHING

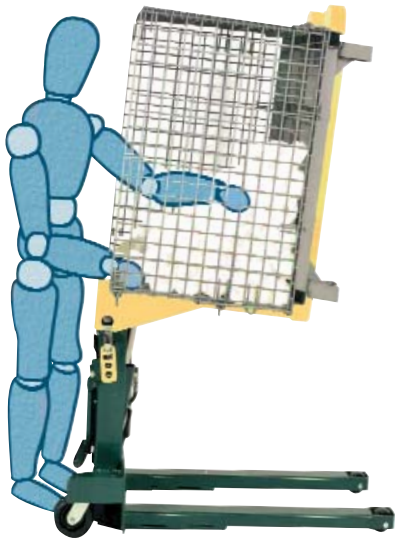

Accessing parts and containers is one of the most significant productivity thieves in any manufacturing or assembly operation. Southworth Container Tilters improve productivity and safety by positioning baskets so that parts are easily accessible without bending, stretching, or reaching.

Southworth offers more models and configurations of container tilters than any other manufacturer. Units are available with capacities up to 4,000 lbs., DC power, hand pallet truck accessibility, and even independent control of lift and tilt. So, no matter what specific machine feeding requirement you have, one of the products shown here can make the job faster, safer, and easier.

In almost every case we've ever seen, production machines work faster than the people feeding them. Getting parts to machines faster not only increases worker productivity, it increases machine productivity, improving R.O.I. and shortening the amount of time it takes for production equipment to "pay for itself", while always improving the safety of the worker.

No matter what type of container or tote you are using, Southworth has a tilter that will make the job of machine feeding faster, safer, and easier.

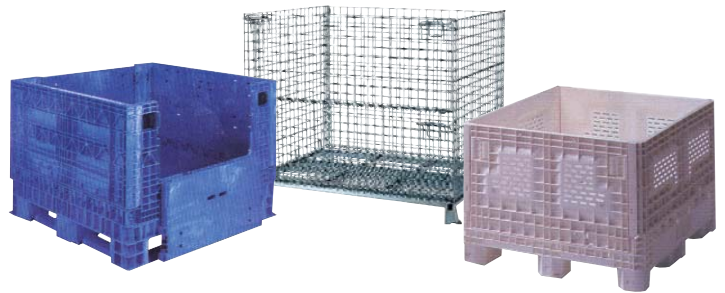

POWERED PORTABLE TILTERS

E-Z REACH E-Z DRIVE

E-Z Reach E-Z Drive™ Tilters combine the best features of "walkies" with our proven E-Z Reach Container Tilter. The powered drive makes it ideal for retrieval and delivery of containers to and from workstations where it can be tilted up to 85° for easy access to parts.

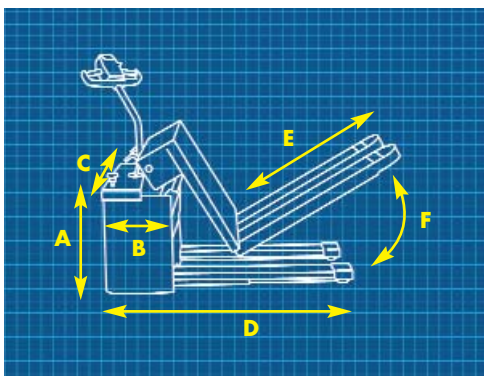
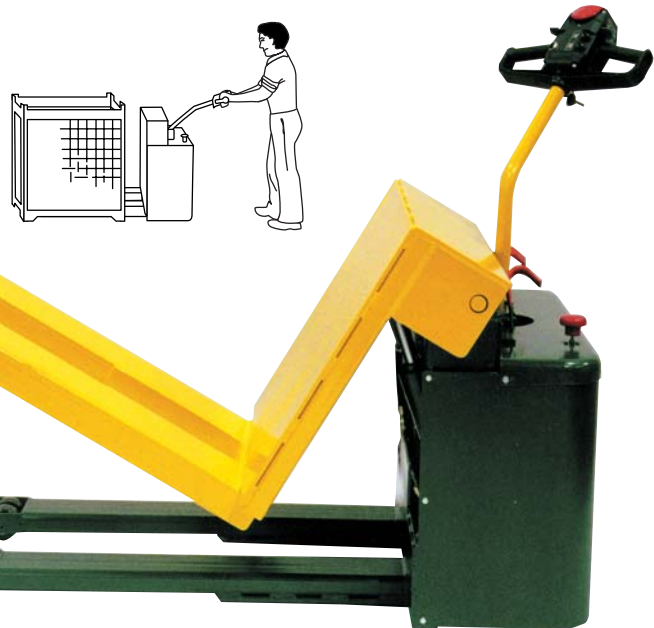

MODEL NO.	CAPACITY	A MAST HEIGHT	B MAST DEPTH	C OVERALL WIDTH	D OVERALL LENGTH	E FORK LENGTH	FORK HEIGHT	FORK OUT TO OUT	FORK WIDTH	F TILT	POWER	APPROX. SHIPPING WEIGHT
MPTU-2	2000 lbs.	31"	18"	36"	58"*	40"	3½"	25½"	8"	85°	24 Volt DC	1350 lbs.
MPTU-4	4000 lbs.	31"	18"	36"	58"*	40"	3½"	25½"	8"	85°	24 Volt DC	1400 lbs.

*81" including handle straight out.

PORTABLE FILTERS

E-Z REACH PORTABLE TILTER (Fork Over Style)

Our most popular container tilter, the E-Z Reach Portable allows staged containers to be picked up, moved into position, and tilted for easy access. Available with DC power for untethered mobility.

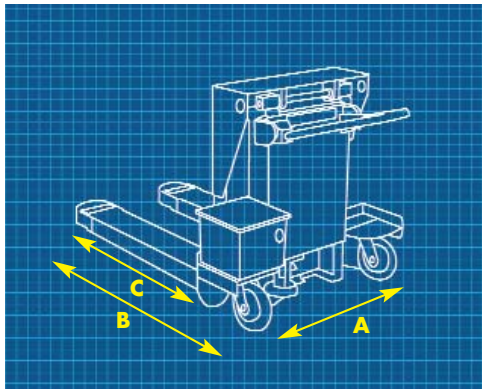

MODEL NO.	CAPACITY	A OVERALL WIDTH	B OVERALL LENGTH	C FORK LENGTH	FORK HEIGHT	TILT	POWER	APPROX. SHIPPING WEIGHT
PTU-2	2000 lbs.	34"	54"	40"	3½"	85°	12 Volt DC	650 lbs.
PTU-4	4000 lbs.	33¾"	61½"	41¾"	3½"	85°	12 Volt DC	870 lbs.

Units are furnished with either push-button or foot switch control.

E-Z REACH PORTABLE TILTER (Straddle Style)

The E-Z Reach Portable Straddle configuration is designed specifically for containers with leg reinforcing bars or closed bottoms.

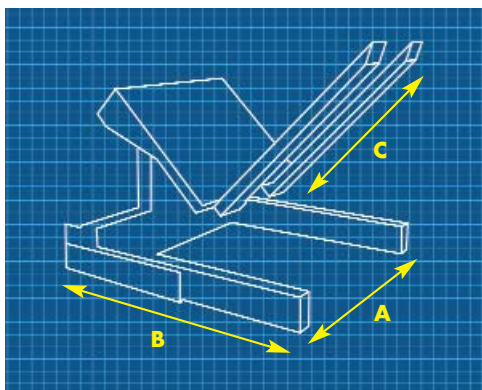

If your container looks like this choose Straddle

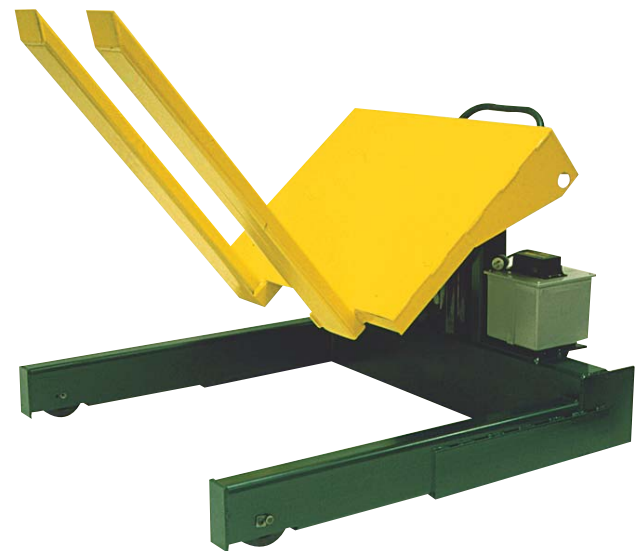
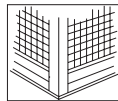

MODEL NO.	CAPACITY	A OVERALL WIDTH	B OVERALL LENGTH	C FORK LENGTH	FORK HEIGHT	TILT	POWER	APPROX. SHIPPING WEIGHT
SPTU-2	2000 lbs.	57"	54"	40"	3½"	85°	12 Volt DC	950 lbs.
SPTU-4	4000 lbs.	57"	58"	40"	3½"	85°	12 Volt DC	1100 lbs.

Units are furnished with either push-button or foot switch control.

HAND PALLET TRUCK ACCESSIBLE TILTERS

E-Z REACH ROLL-ON™ TILTER

With fork channels that allow either hand pallet trucks or fork trucks to place containers directly on the tilter in a single step, the Roll-On E-Z Reach is designed for stationary installation at work stations.

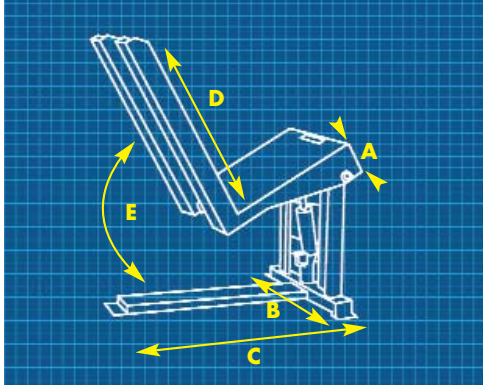
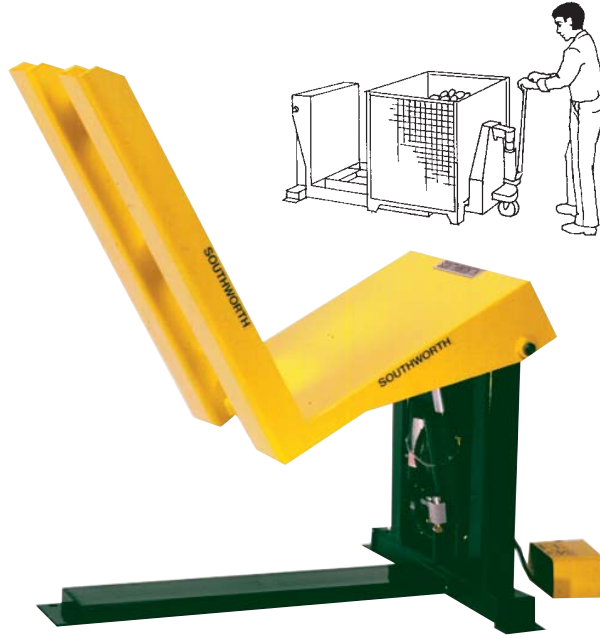

MODEL NO.	CAPACITY	A MAST DEPTH	B OVERALL WIDTH	C OVERALL LENGTH	D FORK LENGTH	FORK OUT TO OUT	FORK WIDTH	E TILT	POWER	APPROX. SHIPPING WEIGHT
ZTU-2	2000 lbs.	7"	42"	47"	40"	29"	8"	85°	115/1/60	650 lbs.
ZTU-4	4000 lbs.	7"	42"	47"	40"	29"	8"	85°	115/1/60	700 lbs.

Units are furnished with either push-button or foot switch control.

E-Z REACH UNIVERSAL TILTER

The wide, unobstructed container pan of the Universal E-Z Reach allows containers of all types, even those with leg reinforcing bars, to be placed directly on the tilter in a single step by either fork trucks or hand pallet trucks. The wide pan even accepts oversized containers.

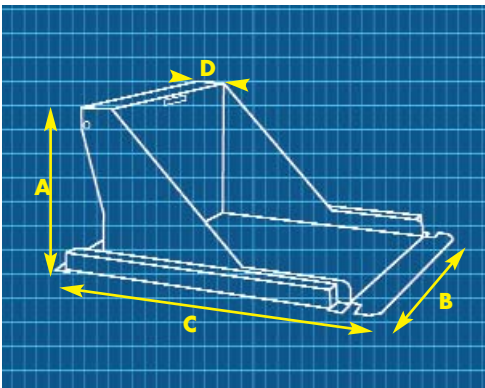
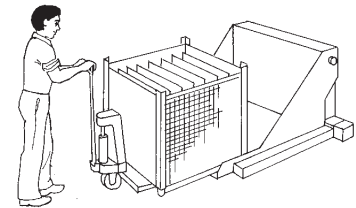

MODEL NO.	CAPACITY	A MAST HEIGHT	B OVERALL WIDTH	C OVERALL LENGTH	D MAST DEPTH	LOW HEIGHT	USABLE PAN SIZE	TILT	STD. POWER	APPROX. SHIPPING WEIGHT
ZTU-2 Pan	2000 lbs.	31½"	62½"	65¼"	7"	3/8"	50" X 50"	85°	115/1/60	1150 lbs.
ZTU-4 Pan	4000 lbs.	31½"	62½"	65¼"	7"	3/8"	50" X 50"	85°	115/1/60	1170 lbs.

Units are furnished with either push-button or foot switch control.

STATIONARY TILTERS

E-Z REACH LIFT AND TILT – HYDRAULIC OR PNEUMATIC ACTUATION

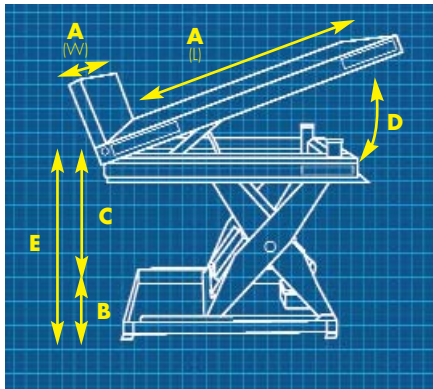

To precisely position containers with independent control of lift and tilt, E-Z Reach Lift and Tilt is ideal. With its exclusive Universal Tilter Base (UTB) it compensates for the shifting center of gravity as the load is tilted. The open frame top allows the tilting hydraulics to retract within the frame resulting in a lower profile when in the full down position. The UTB also combines a shorter but wider stance for improved stability in a minimum footprint.

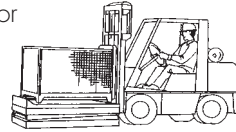

Hydraulic

MODEL NO.	CAPACITY	A STANDARD PLATFORM W x L	A MAX PLATFORM W x L	B LOWERED HEIGHT	C TRAVEL VERTICAL	D TRAVEL ANGULAR	E RAISED HEIGHT	POWER REQUIRED	APPROX SHIPPING WEIGHT
UTB1	1000	42" x 42"	66" x 72"	11"	28"	30° or 45°	39"	115/1/60	1100 lbs.
UTB2	2000	42" x 42"	66" x 72"	11"	28"	30° or 45°	39"	115/1/60	1150 lbs.
UTB4	4000	42" x 42"	66" x 54"	11"	28"	30° or 45°	39"	115/1/60	1200 lbs.

Pneumatic

LTA2-24	2000 lbs.	30" x 48"	48" x 72"	14½"	24"	30° or 40°	38½"	80psi/80cfm*	900 lbs.
LTA4-24	4000 lbs.	44" x 48"	66" x 56"	14½"	24"	30° or 40°	38½"	80psi/80cfm*	1000 lbs.

*Free Air

FIXED HEIGHT TILTER – HYDRAULIC OR PNEUMATIC ACTUATION

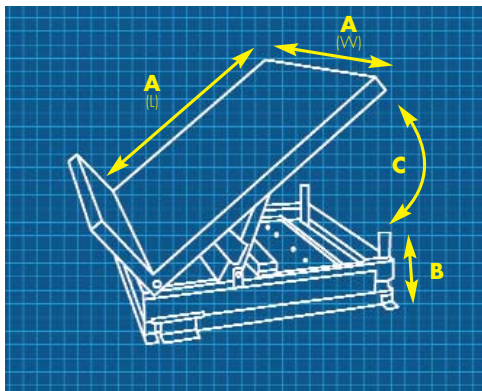

For applications utilizing small or shallow containers that do not require vertical repositioning, the Fixed Height Tilter is the ideal choice. Available in 2000 lbs. and 4000 lbs. They can be mounted on the floor or a fixed height table top.

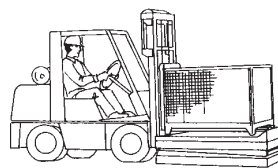

Hydraulic

MODEL NO.	CAPACITY	A STANDARD PLATFORM W x L	A MAX PLATFORM W x L	B LOWERED HEIGHT	C TRAVEL ANGULAR	POWER REQUIRED	APPROX SHIPPING WEIGHT
T2-45	2000 lbs.	24" x 36"	48" x 48"	7½"	30° or 45°	115/1/60	600 lbs.
T4-45	4000 lbs.	24" x 36"	48" x 48"	7½"	30° or 45°	115/1/60	650 lbs.

Pneumatic

TA2-40	2000 lbs.	26" x 48"	48" x 72"	9"	30° or 40°	80psi/80cfm*	650 lbs.
TA4-40	4000 lbs.	42" x 48"	66" x 56"	9"	30° or 40°	80psi/80cfm*	750 lbs.

*Free Air