

# MODEL 796LSZ W/SENSOR ROLLERS LINE SHAFT ZERO PRESSURE ACCUMULATOR

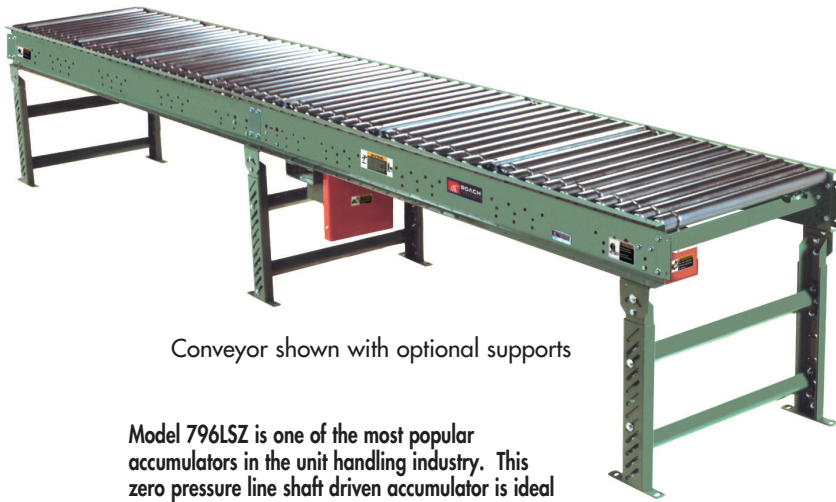

Conveyor shown with optional supports

Model 796LSZ is one of the most popular accumulators in the unit handling industry. This zero pressure line shaft driven accumulator is ideal for numerous light to medium duty applications. Curves, spurs and other line shaft modules may be driven by a SINGLE drive.

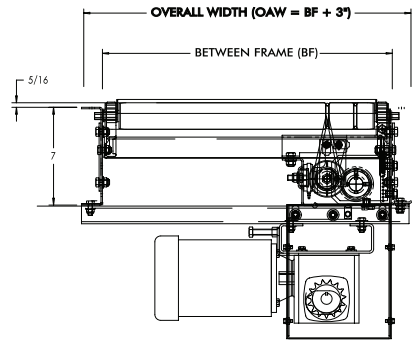

### LINE SHAFT COUPLING CHART

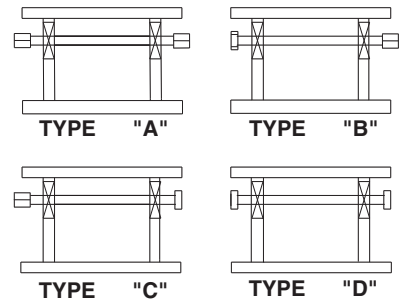

HP@ 60 FPM	"A" MAX
1/3, 1/2	21"
3/4, 1	22"
1-1/2, 2	23"

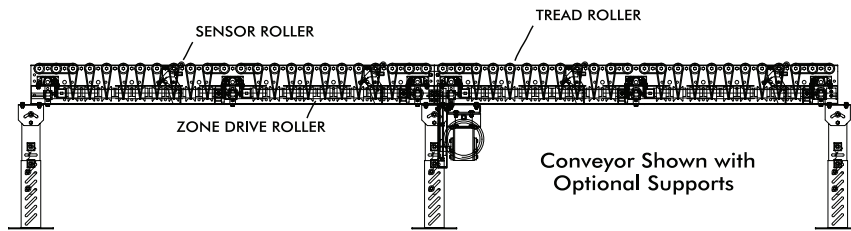

## SPECIFICATIONS

**TREAD ROLLERS:** 1.9" dia. x 16 ga. steel, model 196S grooved.

**DRIVE BELT:** 3/16" dia., polyurethane belts. Nominal 15 lbs. per roller drive.

**DRIVE SHAFT:** 1" dia. C1018 cold rolled steel shaft.

**COUPLINGS:** Couplings located both ends (type "A"), one end only (type "B" or "C") or none (type "D"). See 'line shaft coupling chart' and specify.

**CENTER DRIVE:** Located approximately 16-1/2" from end of bed section on 4" RC; 18" on 3" and 6" RC.

**SPEED:** 60 FPM, constant.

**ACCUMULATION ZONE:** 2'-0" zone length, pneumatically actuated, zone singulation operation.

**BEARINGS:** All bearings are precision, lubricated, ball bearing units with composite housings.

**BED:** 7" x 1-1/2" x 12 ga. formed steel channel frame. Bed sections attached with splice plates and floor supports.

**FRL:** Unit is provided with filter, regulator, lubricator with 1/4" ports.

**PNEUMATIC ACTUATION:** Maximum air line pressure should not exceed 30 PSI.

**MOTOR DRIVE:** 1/3 HP, 230/460/3, 60 cycle, ODP right angle gear motor.

**ROLLER CHAIN:** Drive shaft is driven by No. 50 chain. Chain take-up provided on motor base.

**CAPACITY:** See technical section for load capacity rating.

**ELECTRICAL CONTROLS:** Optional.

## SPECIFICATION TABLE

■ 3 week shipment

CONVEYOR LENGTH		10'	20'	30'	40'	50'	60'	70'	80'	90'	100'	Deduct
BF	OAW	UNIT WEIGHTS (lbs.) with 3" Roller Centers (For other centers, deduct weights below)										Per Foot
15"	18"	551	928	1306	1683	2061	2438	2816	3193	3571	3948	38
19"	21"	589	1003	1417	1831	2244	2658	3072	3486	3900	4313	41
21"	24"	612	1049	1486	1923	2360	2797	3234	3671	4108	4545	44
25"	28"	646	1130	1613	2096	2580	3063	3546	4029	4513	4996	48
27"	30"	672	1178	1684	2191	2697	3203	3710	4216	4722	5229	51
33"	36"	724	1300	1876	2452	3027	3603	4179	4755	5331	5906	58
39"	42"	788	1504	2079	2724	3369	4015	4660	5305	5950	6595	72

Deduct the following weights (lbs.) for other than 3" centers

Tread Roller Centers	15" BF		19" BF		21" BF		25" BF		27" BF		33" BF		39" BF	
	Per 5'	Per 10'	Per 5'	Per 10'	Per 5'	Per 10'	Per 5'	Per 10'	Per 5'	Per 10'	Per 5'	Per 10'	Per 5'	Per 10'
4"	-14	-28	-17	-34	-19	-37	-21	-42	-23	-45	-27	-53	-31	-62
6"	-18	-36	-34	-68	-37	-74	-42	-84	-45	-90	-53	-106	-62	-124

## OPTIONAL EQUIPMENT

**SIDE MOUNTED DRIVE:** Provides overall conveyor height of 10".

**ACCUMULATION ZONES:** 18" and 30" long zones available, depending on roller centers.

**ACCUMULATION CONTROLS:** For actuation of zones using photo electric sensors, see pages 70-71 for model SZ796LSA SMART ZONE®.

**GALVANIZED ROLLERS:** Tread rollers available in galvanized steel, model 196G.

**FLOOR SUPPORTS:** Other height supports, knee braces, casters, polyier supports and ceiling hangers available. See pg. 125-129.

**CONVEYOR SPEED:** Constant speed 15-120 FPM; DC variable speed; AC inverter variable speed. MINIMUM operating speed for line shaft conveyor is 30 FPM.

**MOTORS:** Available through 2 HP in TEFC, explosion proof, dirty duty, 115/230/1, 575/3, etc.

**GUARD RAILS:** 1-3/4" x 1" formed channel (model GC), adjusts horizontally to 8" wider than roller and vertically to 6" above roller; formed steel fixed (model FSG in 2", 4" and 6" heights; fixed channel (model FC); 1-1/2" angle (model GA1-1/2). See Conveyor Accessories.

**ELECTRICAL CONTROLS:** One direction magnetic or manual starter; momentary start/stop push button station. Mounting and pre-wiring for units up to 12' long.

## PNEUMATIC FLOW CHART

NOTE: Pneumatic flow must be specified as shown in diagram below

