

# MODEL 505 Medium Duty Inclining Conveyor



This unit features a 13" deep frame, 3" high cleats, 6" high side rails and large drive pulley. It is designed to move larger and heavier products up inclines. This sturdy, solid conveyor is built to last and withstand heavy usage.

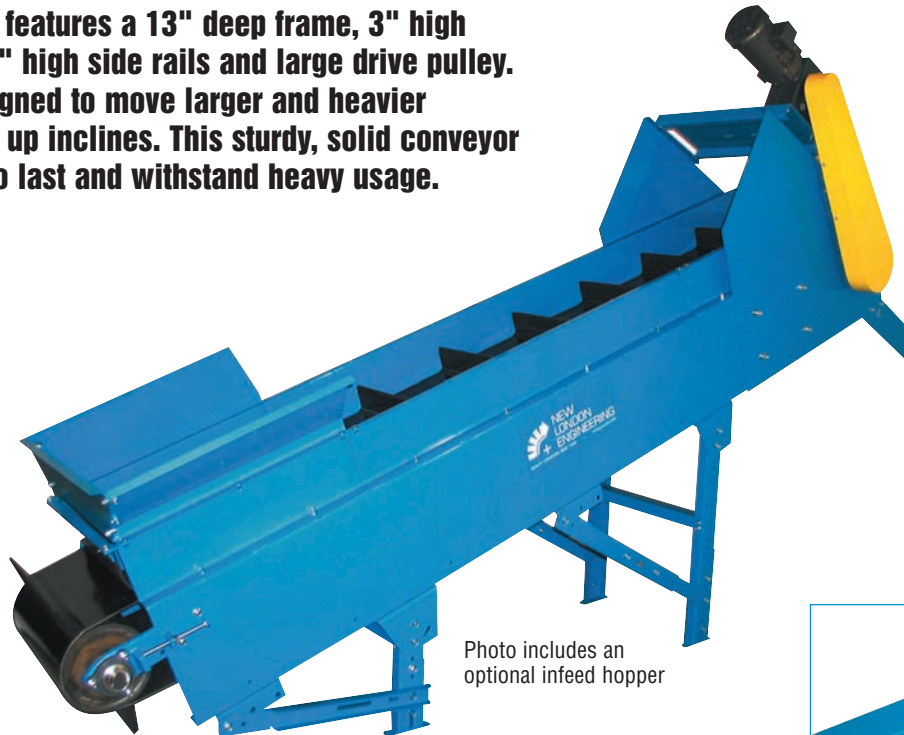
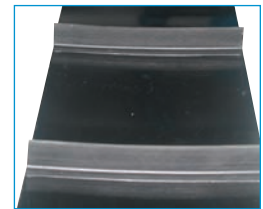

Photo includes an optional infeed hopper

Flared infeed hopper



Belt shown with cleats



Unit shown with bottom mount drive



<b>Belt Width:</b>	12"	18"	24"	30"	36"	48"
<b>Frame Width:</b>	15"	21-1/2"	28"	34"	40"	52"

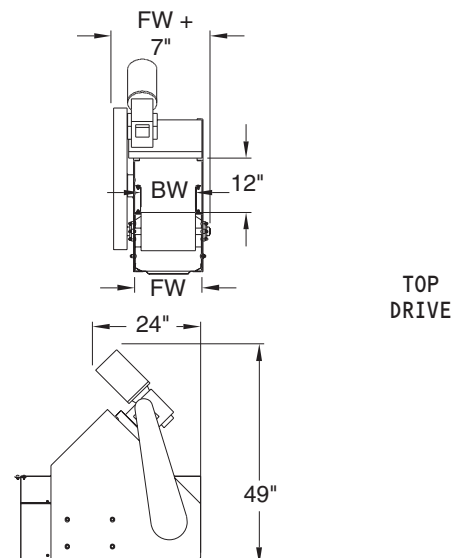
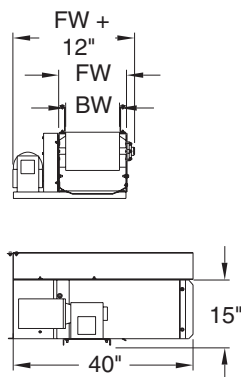
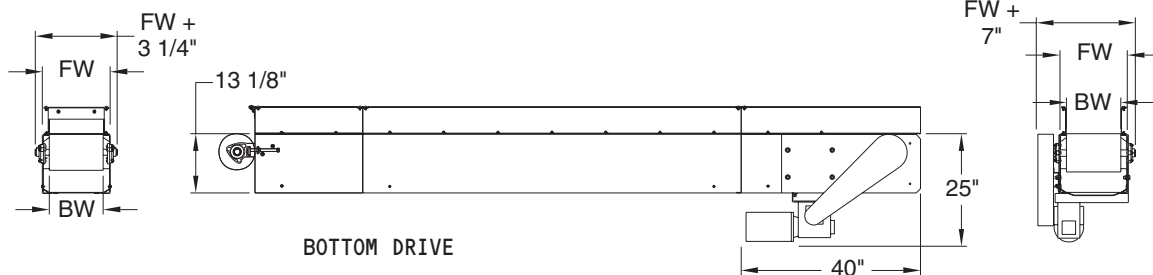

# MODEL 505 Medium Duty Inclining Conveyor



## Standard Specifications

**Widths:** 12" – 48"  
**Lengths:** 5' – 25' (6" Increments)  
 Standard Length is 5', Two Piece Bolt Together  
**Standard Speed:** 60 FPM  
**Standard Motor:** 3/4 HP 230/460/3/60 TEFC  
**Standard Drive:** Top Mount, Right Side  
**Standard Belt:** Black PVC 120 with 3" high cleats on 12" centers, Clipper Lacing

**Drive Pulley:** 8" Dia Crown Face Rubber Lagged x 1-7/16"  
**Infeed Pulley:** 8" Dia Crown Face Take Up x 1-7/16"  
**Frame:** 13" Deep x 10 Gauge  
**Bearings:** Grease Sealed  
**Others:** Base unit includes 6" high side rails and bottom pan

## Inclined Conveyors – Horizontal Inclined Units Comparison Chart

**Inclined Conveyors – Horizontal Inclined Units** — These units use cleated belts to carry loose, unpacked items like plastic parts, nuts & bolts and stampings up inclines

MODEL	DESCRIPTION	FRAME GAUGE	FRAME DEPTH	DRIVE PULLEY SIZE	DRIVE PULLEY TYPE*	DRIVE PULLEY SHAFT DIA.	INFEED PULLEY SIZE	INFEED PULLEY TYPE*	INFEED PULLEY SHAFT DIA.	STANDARD BELT	STD. DRIVE*	OTHER
150	Standard duty low profile inclining conveyor	12	1.75" + cleat height	2.875"	CF knurled pulley	.75"	1.3125"	FF pulley	.5"	2 ply black PVC 70	Bottom	Note: Frame depth changes with cleat height
500	Standard duty inclining conveyor	12	6.625"	4.625"	CFRL pulley	1.1875"	4"	CF pulley	1.1875"	2 ply black PVC 120 with 1-1/2" cleats on 12" centers	Top	Unit includes 1-1/2" or 3/12" rails and a bottom pan
505	Medium duty inclining conveyor	10	13"	8.625"	CFRL pulley	1.4375"	8"	CF pulley	1.4375"	2 ply black PVC 120 with 3" cleats on 12" centers	Top	Unit includes 6" high siderails
506	Heavy duty inclining conveyor	10	13"	8.625"	CFRL pulley	1.6875"	8"	CF pulley	1.4375"	2 ply black PVC 120 with 3" cleats on 12" centers	Top	Heavy drive shaft M505
351	Standard duty V-guided inclining conveyor	12	6.625"	4.625"	FFRL "A" section	1.1875"	4"	FF "A" section	1.1875"	2 ply black PVC 120 with 1-1/2" cleats on 12" centers "A" section	Top	V-guided M500

\*BM = Bottom Mount; CF = Crown Faced; CDBM = Center Drive Bottom Mount; CH = Channel; FF = Flat Faced; RL = Rubber Lagged; RA = Right Angle; Std = Standard

## Unit Weights (Shipping Weights – lbs.)

BELT WIDTHS	12"	18"	24"	30"	36"	40"	48"
<b>LENGTHS</b>							
5'	503	558	613	664	715	766	818
10'	660	757	840	916	993	1080	1168
15'	853	993	1105	1207	1311	1435	1560
20'	1010	1192	1332	1459	1589	1749	1910
25'	1203	1428	1597	1750	1907	2104	2302
30'	1360	1627	1824	2002	2185	2418	2652

Conveyor weights include standard drive, supports and 6" high siderails. Other options, crating etc. are not included.

## Skid Dimensions

**Model 505** — Note: these are general guidelines for freight rate estimates only. Final dimensions may vary.

BELT WIDTHS	12"	18"	24"	30"	36"	48"
Bottom, Top & Center Mount <b>Skid Width</b>	25"	30"	41"	41"	47"	59"
Shaft and Side Mount <b>Skid Width</b>	30"	41"	41"	46"	52"	64"

**Skid Length** – These units are typically shipped assembled. The skid length is the overall length + 12". Maximum skid length is 27'.