

Newcastle Company, Inc.

Floor Level Automatic Case Palletizer Model 100-57A

Phone: 724-658-4516 ■ Fax: 724-658-5100 ■ E-Mail: ncco@newcastleco.com



Features

- Floor level infeed
- Interlocking and column stack patterns
- Low to medium speed



100-57A Floor Level Automatic Case Palletizer

Description

The 100-57A is fully automatic and operates at floor level. It handles trays and cases at speeds up to 20 cases per minute. The 100-57A has been designed for single line, low volume operation.

Operation

Cases entering the metering belt are conveyed and turned, forming rows for desired pallet patterns. Full layers are transferred to positioned pallet with a stripper plate. Sequence is repeated, forming full load. The product is then discharged to a power accumulation conveyor.

Optional Equipment

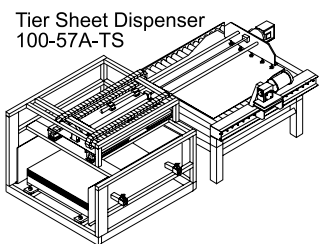

Tier Sheet Dispenser
100-57A-TS

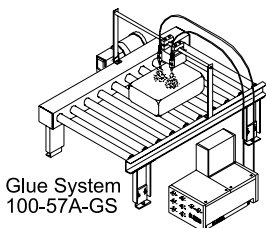

Glue System
100-57A-GS

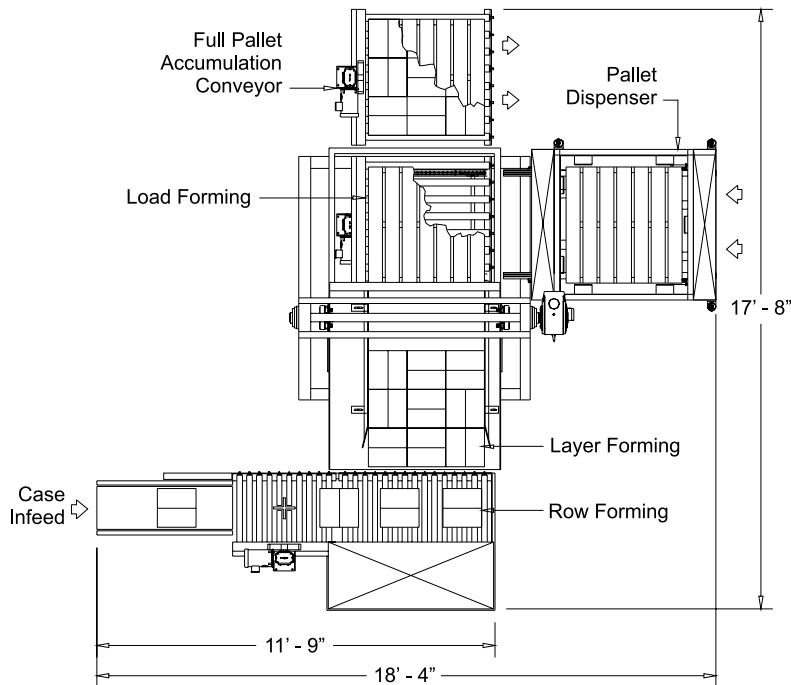

Configurations

