

Newcastle Company, Inc.

Automatic Drum Palletizer Model 100-57D

Phone: 724-658-4516 ■ Fax: 724-658-5100 ■ E-Mail: ncco@newcastleco.com



100-57D Automatic Drum Palletizer

Features

- Completely automatic
- Heavy duty construction
- Multiple patterns
- Handles 15, 30 and 55 gallon drums

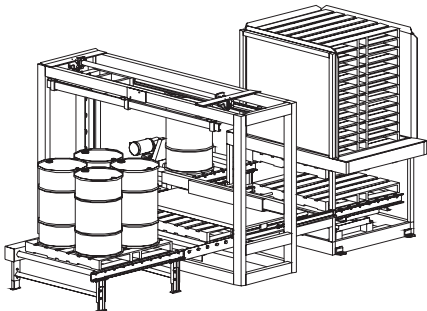

Description

The Model 100-57D is designed to automatically palletize full drums onto a wood pallet or plastic pallet. Several models are available to suit most applications.

This system handles 55 gallon drums at a rate of 4 drums per minute. Drums are transferred from an infeed conveyor to a stripper plate that retracts and deposits drums on pallet. This totally hydraulic system includes a pallet dispenser, drum palletizer, drum infeed conveyor and a full pallet discharge conveyor.

Operation

Empty pallets are stored in a magazine, dispensed and positioned for drum placement. A powered infeed conveyor stages drums for transfer. Drums are transferred to a stripper plate with hydraulic push bar. The stripper plate then retracts, placing drums on pallet. Full pallets are discharged for removal by fork truck.

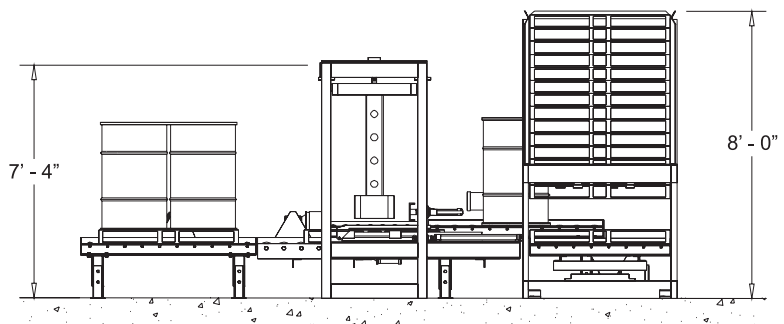
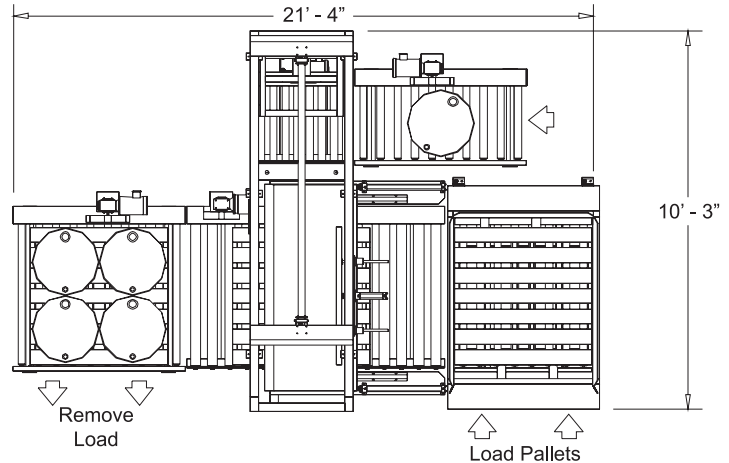

Configurations

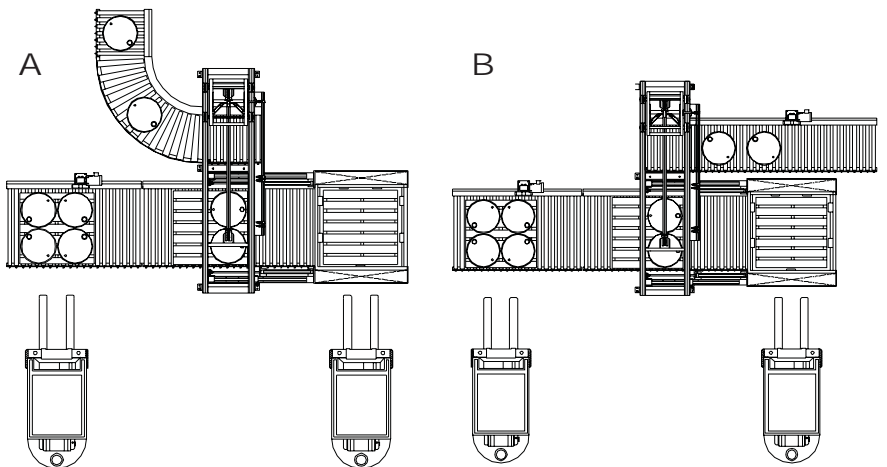

Drum Patterns

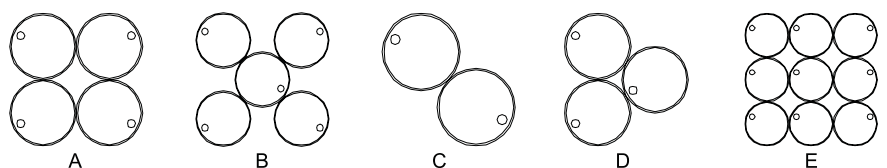

Newcastle Company, Inc.

Automatic Drum Palletizer Model 100-57D



Phone: 724-658-4516 ■ Fax: 724-658-5100 ■ E-Mail: ncco@newcastleco.com



100-57D Automatic Drum Palletizer with Infeed Drum Staging Conveyors



Drum Rotator
for Labeling and Filling



100-57D Palletizes Fiber Drums



100-57D Palletizes Plastic Drums



100-57D with Drum Infeed Conveyors and Scale



100-57D Palletizes 55 Gallon Steel Drums