

# Newcastle Company, Inc.

## Load Clamp System Model RM-1350

Phone: 724-658-4516 ■ Fax: 724-658-5100 ■ E-Mail: [ncco@newcastleco.com](mailto:ncco@newcastleco.com)



The Clamp Assembly Elevates



The Top Half of the Load is Clamped



The Product is Separated

### Features

- Clamps and lifts cased products
- Automatic in-line operation
- 3,000 pound capacity

### Description

The RM-1350 is used to split double loads or transfer unitized product to pallets.

### Operation

Product is conveyed into position. For double load splitting, the load is measured. The clamp assembly travels vertically to its split line. The top half of the load is then clamped and lifted, allowing the lower half of the load to exit. The suspended load is then lowered and released.

To transfer product, the product is clamped and lifted from the conveyor. The pallet is then dispensed and positioned under the suspended product. Finally, the load is lowered and placed on the pallet.

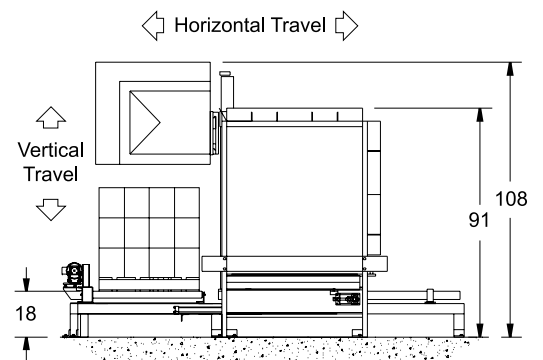
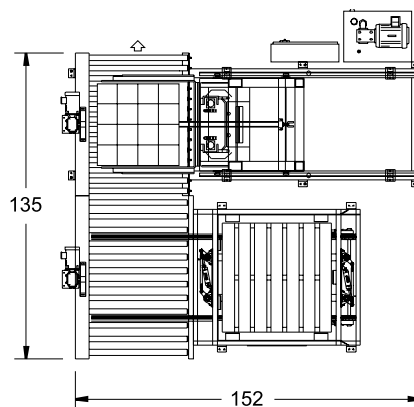
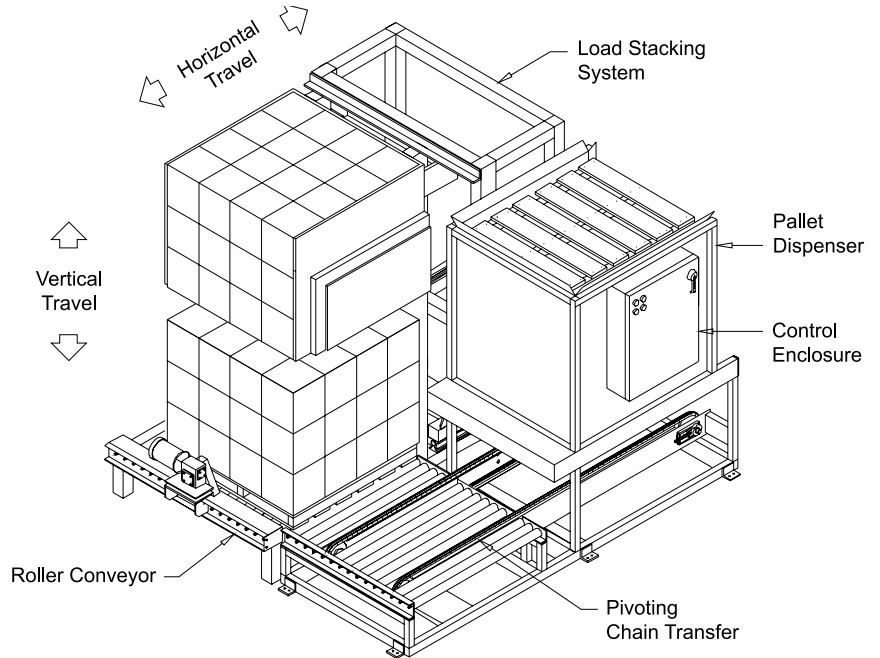

RM-1350 Pallet to Pallet Load Transfer System with Clamp and Dispenser