

MODEL 796LS LINE SHAFT DRIVEN LIVE ROLLER

24 HOUR SHIPMENTS INCLUDE ALL 1-FOOT INCREMENTS 2'-0" TO 100'-0"

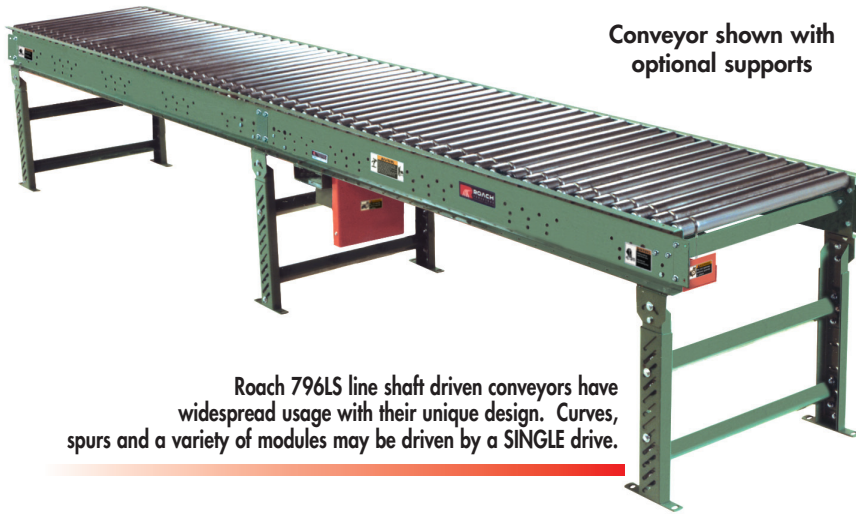

Conveyor shown with optional supports

Roach 796LS line shaft driven conveyors have widespread usage with their unique design. Curves, spurs and a variety of modules may be driven by a SINGLE drive.

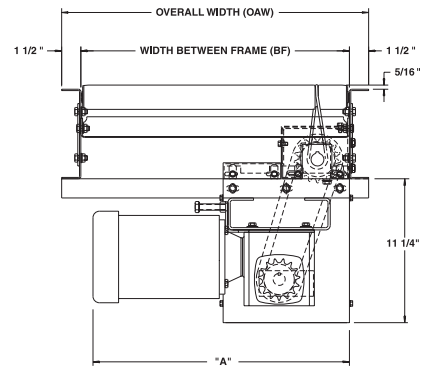
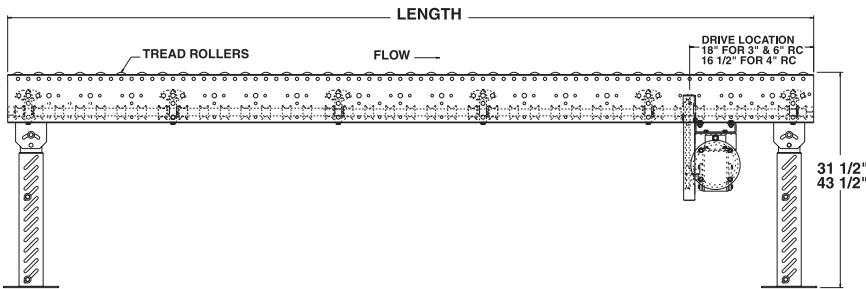

LINE SHAFT COUPLING CHART

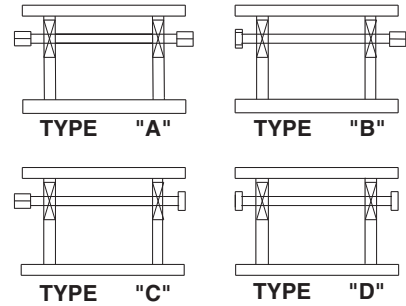

HP@ 60 FPM	"A" MAX
1/3, 1/2	21"
3/4, 1	22"
1-1/2, 2	23"

SPECIFICATIONS

TREAD ROLLERS: 1.9" dia. x 16 ga. steel, model 196S grooved.

DRIVE BELT: 3/16" dia., polyurethane belts. Nominal 15 lbs. per roller drive.

DRIVE SHAFT: 1" dia. C1018 cold rolled steel shaft.

COUPLINGS: Couplings located both ends (type "A"), one end only (type "B" or "C") or none (type "D"). See 'line shaft coupling chart' and specify.

CENTER DRIVE: Reversible drive; located approximately 18" from end of bed section for 3" and 6" RC; 16-1/2" for 4"RC.

BEARINGS: Precision, lubricated, ball bearing units with composite housings.

SPEED: 60 FPM, constant.

BED: 7" x 1-1/2" x 12 ga. formed steel channel frame. Bed sections attached with splice plates and floor supports.

MOTOR DRIVE: 1/3 HP, 230/460/3, 60 cycle, ODP right angle gear motor.

ROLLER CHAIN: Drive shaft is driven by No. 50 chain. Chain take-up provided on motor base.

CAPACITY: See Technical Section for load capacity rating.

ELECTRICAL CONTROLS: Optional.

SPECIFICATION TABLE

■ 24 hour shipment

CONVEYOR LENGTH		10'	20'	30'	40'	50'	60'	70'	80'	90'	100'	Deduct
BF	OAW	UNIT WEIGHTS (lbs.) with 3" Roller Centers (For other centers, deduct weights below)										Per Foot
15"	18"	319	561	803	1044	1286	1528	1770	2011	2253	2495	24
19"	22"	349	617	886	1154	1423	1691	1960	2228	2497	2765	27
21"	24"	363	645	927	1209	1491	1773	2054	2336	2618	2900	28
25"	28"	393	701	1010	1319	1627	1936	2244	2553	2861	3170	31
27"	30"	408	729	1051	1373	1695	2017	2339	2661	2983	3305	32
33"	36"	452	814	1176	1538	1900	2262	2624	2986	3348	3710	36
39"	42"	496	898	1300	1702	2104	2507	2909	3311	3713	4115	40

Deduct the following weights (lbs.) for other than 3" centers

Tread Roller Centers	15" BF		19" BF		21" BF		25" BF		27" BF		33" BF		39" BF	
	Per 5'	Per 10'	Per 5'	Per 10'	Per 5'	Per 10'	Per 5'	Per 10'	Per 5'	Per 10'	Per 5'	Per 10'	Per 5'	Per 10'
4"	-14	-28	-17	-34	-19	-37	-21	-42	-23	-45	-27	-53	-31	-62
6"	-28	-56	-34	-68	-37	-74	-42	-84	-45	-90	-53	-106	-62	-124

OPTIONAL EQUIPMENT

SIDE MOUNTED DRIVE: Provides overall conveyor height of 10".

FLOOR SUPPORTS: Supports, knee braces, casters and polyfrier supports available. See Conveyor Accessories.

CEILING HANGERS: 5/8" dia. threaded rod with hardware to attach rods to conveyor. Provides 6' clearance between ceiling and TOR (furnished in place of floor supports). See Conveyor Accessories.

CONVEYOR SPEED: Constant speed 15-120 FPM; DC variable speed; AC inverter variable speed. **MINIMUM** operating speed for line shaft conveyor is 30 FPM.

GALVANIZED ROLLERS: Tread rollers available in galv. steel, model 196G.

GUARD RAILS: 1-3/4" x 1" formed channel (model GC), adjusts horizontally to 8" wider than roller and vertically to 6" above roller; formed steel fixed (model FSG in 2", 4" and 6" heights; fixed channel (model FC); 1-1/2" angle (model GA1-1/2). See Conveyor Accessories.

MOTORS: Available through 2 HP in TEFC, explosion proof, dirty duty, 115/230/1, 575/3, etc.

ELECTRICAL CONTROLS: Magnetic starter (one direction or reversible); One direction manual starter; Momentary start/stop push button station; Forward/reversing /stop push button. Mounting and pre-wiring for units up to 12' long.

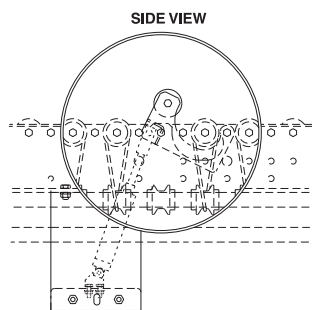

OPTIONAL PNEUMATIC ROLLER STOP

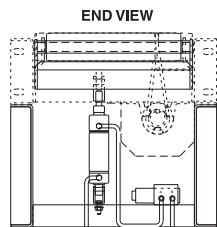

LINE SHAFT BEARING HOUSING