

Lodestar XL electric chain hoist

Columbus McKinnon introduces an expanded line of Lodestar XL electric chain hoists for lifting applications from 2 to 7½ tons. The new offering provides heavy-duty hoists featuring faster speeds, less reeving, and higher capacities than traditional chain hoists. Workers in automotive plants, heavy equipment manufacturing, paper mills, and related rugged work environments will experience the same dependability and versatility that they have relied on for many years.

The NEW features of the Lodestar XL Electric Chain Hoist include:

- Lifting capacities up to 7½ tons
- Increased lifting speeds throughout the line
- Double reeved units with 3-5 ton lifting capacities
- Maximum lifting speed of 30 feet per minute

A glimpse of the many features of the Lodestar XL that have honed its reputation for durability and long life:

- Heavy-duty, multiple disc braking system
- Forged ten-pocket oblique-lay liftwheel for smooth chain operation, constant chain speed, and reduced chain wear
- Gearing operated in oil bath for increased lifting life and quiet operation
- Rated H-4, heavy-duty
- Standard overload protector
- Screw-type limit switches
- Thermally protected motor
- Factory tested at 125% of rated capacity
- Made in U.S.A.
- Lifetime warranty



Capacity (tons)	Reeving	Speed (fpm)	230/460-3-60				575-3-60			
			Hook	Plain Trolley	Geared Trolley	Motor Driven Trolley	Hook	Plain Trolley	Geared Trolley	Motor Driven Trolley
2	1	18	5201H	5201P	5201G	5201M	5231H	5231P	5231G	5231M
2	1	24	5204H	5204P	5204G	5204M	5232H	5232P	5232G	5232M
2	1	30	5265H	5265P	5265G	5265M	5266H	5266P	5266G	5266M
3	2	9	5209H	5209P	5209G	5209M	5233H	5233P	5233G	5233M
3	2	12	5212H	5212P	5212G	5212M	5234H	5234P	5234G	5234M
3	2	15	5267H	5267P	5267G	5267M	5268H	5268P	5268G	5268M
4	2	9	5215H	5215P	5215G	5215M	5235H	5235P	5235G	5235M
4	2	12	5218H	5218P	5218G	5218M	5236H	5236P	5236G	5236M
4	2	15	5269H	5269P	5269G	5269M	5278H	5278P	5278G	5278M
5	3	6	5221H	5221P	5221G	5221M	5237H	5237P	5237G	5237M
5	3	8	5224H	5224P	5224G	5224M	5238H	5238P	5238G	5238M
5	2	9	5279H	5279P	5279G	5279M	5280H	5280P	5280G	5280M
5	2	12	5283H	5283P	5283G	5283M	5284H	5284P	5284G	5284M
5	2	15	5285H	5285P	5285G	5285M	5286H	5286P	5286G	5286M
6	3	6	5227H	5227P	5227G	5227M	5239H	5239P	5239G	5239M
6	3	8	5230H	5230P	5230G	5230M	5240H	5240P	5240G	5240M
6	3	10	5287H	5287P	5287G	5287M	5288H	5288P	5288G	5288M
7½	3	6	—	5289P	5289G	5289M	—	5290P	5290G	5290M
7½	3	10	—	5291P	5291G	5291M	—	5292P	5292G	5292M

3.5 H.P. XL Models (unshaded) – Available in single speed, 3:1; two speed, variable speed

5.5 H.P. XL Models (shaded) – Available in single speed, variable speed

Lodestar XL with hook suspension

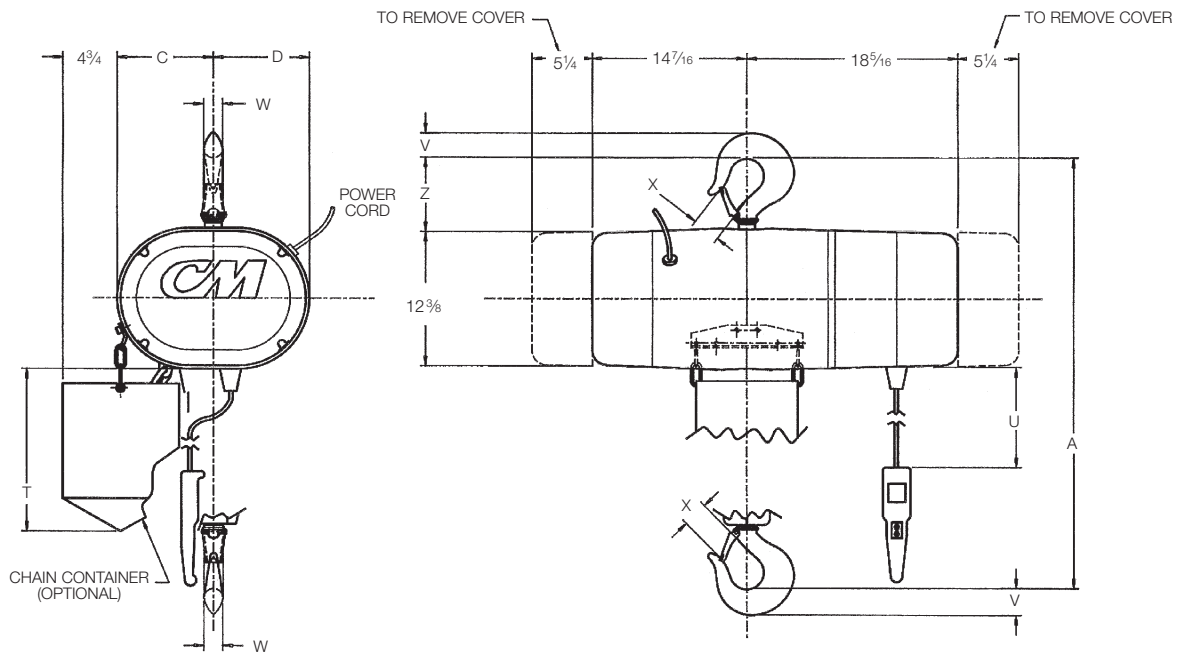

Clearance dimensions (in.)

Dimensions	Single Reeved 2 ton capacity	Double Reeved 3-5 ton capacity	Triple Reeved 5-6 ton capacity
A	25	35 ⁵ / ₁₆	36 ³ / ₁₆
C	8 ⁷ / ₁₆	11 ³ / ₈	11 ³ / ₈
D	8 ¹ / ₈	5 ¹ / ₂	5 ¹ / ₂
T (based on 10 ft. lift)	14 ³ / ₁₆	14 ³ / ₁₆	14 ³ / ₁₆
U (based on 10 ft. lift)	6'- 3"	6'- 3"	6'- 3"
V	1 ¹ / ₂	2 ¹ / ₄	2 ¹ / ₄
W	1 ¹ / ₈	1 ⁵ / ₈	1 ⁵ / ₈
X	1 ⁵ / ₁₆	2 ¹ / ₁₆	2 ¹ / ₁₆
Z	4 ¹ / ₈	5 ¹ / ₂	5 ¹ / ₂



* WARNING

Overloading and improper use can result in injury.

To avoid injury:

- Do not exceed working load limit, load rating capacity
- Do not use to lift people or loads over people.
- use only alloy chain for overhead lifting.
- Read and follow all instructions.

Lodestar XL with plain trolley and geared Trolley

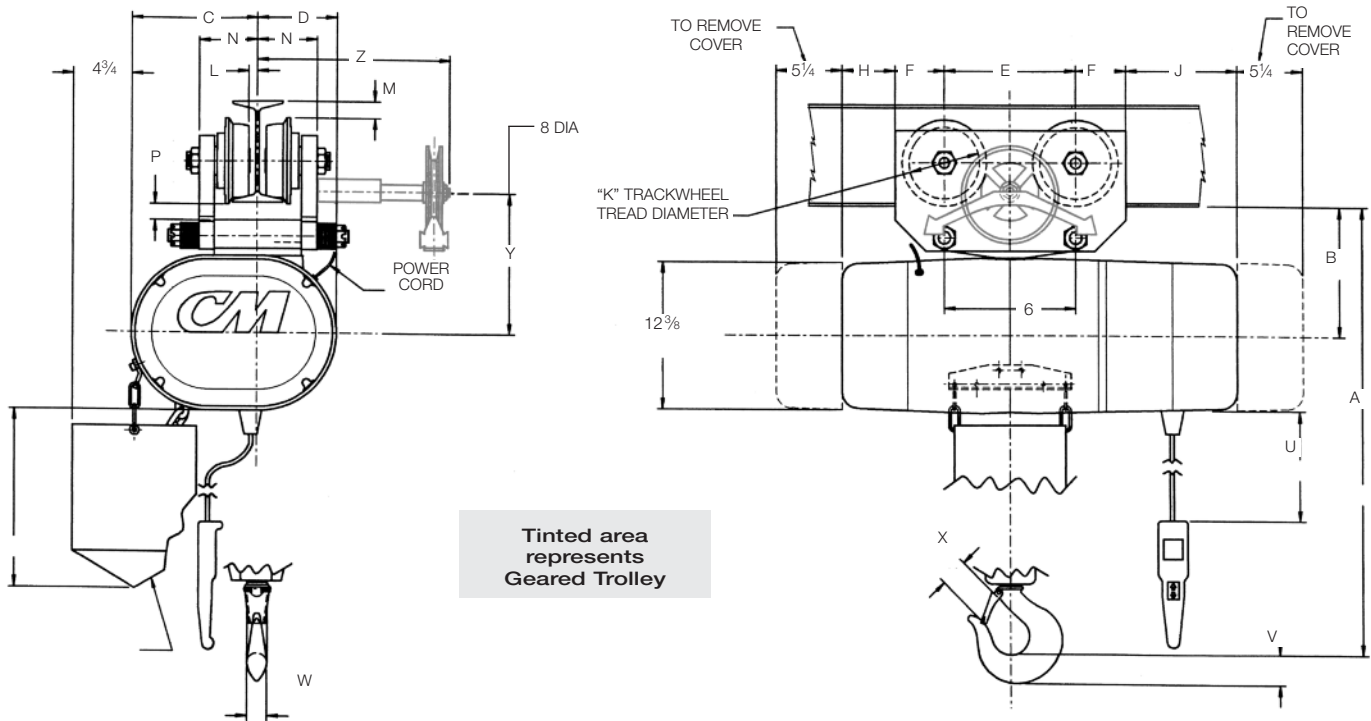

Clearance dimensions (in.)**

Dimensions	Single Reeved 2 ton capacity	Double Reeved		Triple Reeved 5-7 1/2 ton capacity
		3 ton capacity	4 & 5 ton capacity	
A	28 1/16	33 1/2	33 3/4	34 5/8
B	9 3/4	10 7/16	10 11/16	10 11/16
C	8 7/16	11 3/8	11 3/8	11 3/8
D	8 3/8	5 1/2	5 1/2	5 1/2
E	9 1/2	9 1/8	12	12
F	3 1/2	3 1/4	4 13/16	4 13/16
H	5 1/4	5 11/16	2 11/16	2 11/16
J	10 1/16	10 1/2	7 1/2	7 1/2
K	4 1/16	4	6 1/2	6 1/2
L	1/2	5/8	5/8	5/8
M	1/2	2 11/16	0	0
N	5	3 5/8	3 7/8	3 7/8
P	1 1/4	3/8	7/16	7/16
T (based on 10 ft. lift)	14 9/16	14 9/16	14 9/16	14 9/16
U (based on 10 ft. lift)	6' - 3"	6' - 3"	6' - 3"	6' - 3"
V	1 1/2	2 1/4	2 1/4	2 1/4
W	1 1/8	1 5/8	1 5/8	1 5/8
X	1 5/16	2 1/16	2 1/16	2 1/16
Y*	11 5/16	12 7/8	11 1/8	11 1/8
Z*	-	19 1/8	19 1/8	19 1/8
Minimum Radius Curve (ft.)	4	4	6	6
Standard Beam Flange Adj. Range (in.)	3.33-5.55	4.00-6.25	4.00-6.25	4.00-6.25

*Geared Trolley Dimensions Only

**Dimensions listed are for minimum size "S" beam.



Lodestar XL with motor driven trolley (2 ton)

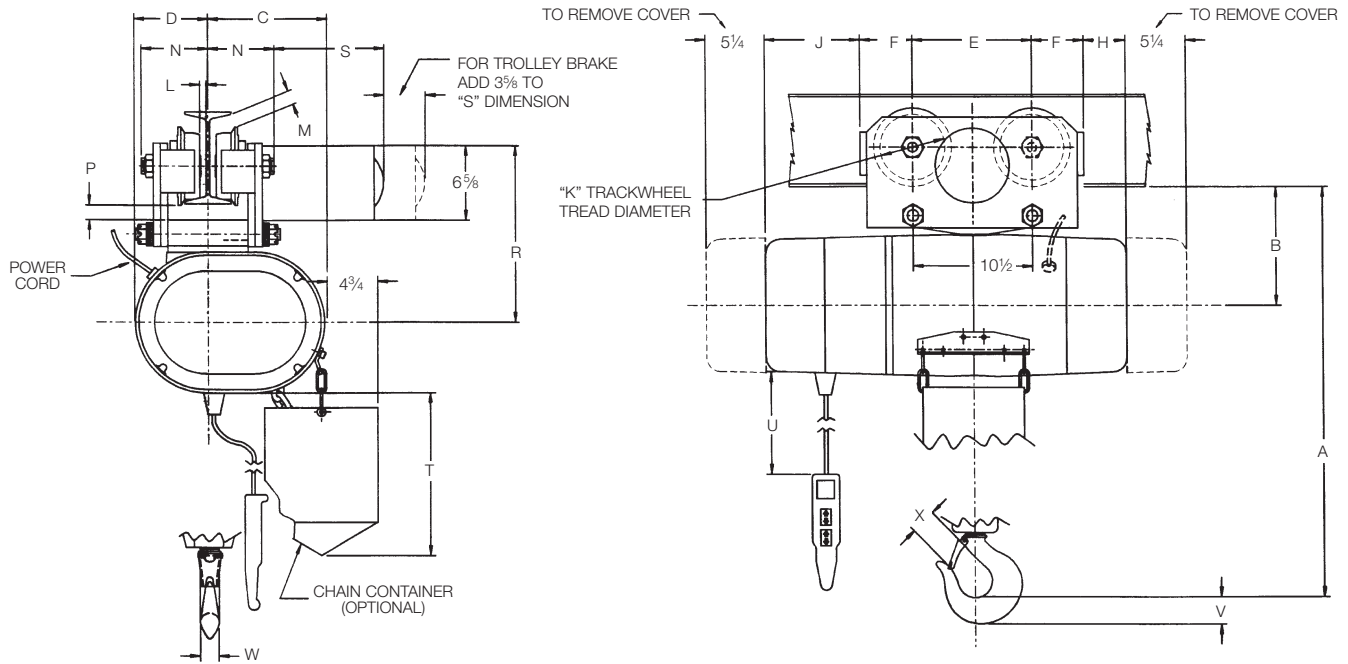

Clearance dimensions (in.)**

Dimensions	Single Reeved 2 ton capacity
A	28 ¹¹ / ₁₆
B	9 ³ / ₄
C	8 ⁷ / ₁₆
D	8 ¹ / ₈
E	9 ¹ / ₂
F	3 ¹ / ₂
H	5 ¹ / ₄
J	10 ¹ / ₁₆
K	4 ¹¹ / ₁₆
L	¹ / ₂
M	¹ / ₂
N	5
P	1 ¹ / ₄
R	14 ⁵ / ₈
S	12 ⁷ / ₁₆
T (based on 10 ft. lift)	14 ³ / ₁₆
U (based on 10 ft. lift)	6' - 3"
V	1 ¹ / ₂
W	1 ¹ / ₈
X	1 ⁵ / ₁₆
Minimum Radius Curve (ft.)	4
Standard Beam Flange Adj. Range (in.)	3.33-5.55
Trolley Speed (ft./min) Standard Single Speed	65 or 100

**Dimensions listed are for minimum size "S" beam.



* ⚠ WARNING

Overloading and improper use can result in injury.

To avoid injury:

- Do not exceed working load limit, load rating capacity
- Do not use to lift people or loads over people.
- use only alloy chain for overhead lifting.
- Read and follow all instructions.

Lodestar XL with motor driven trolley (3-7½ ton)

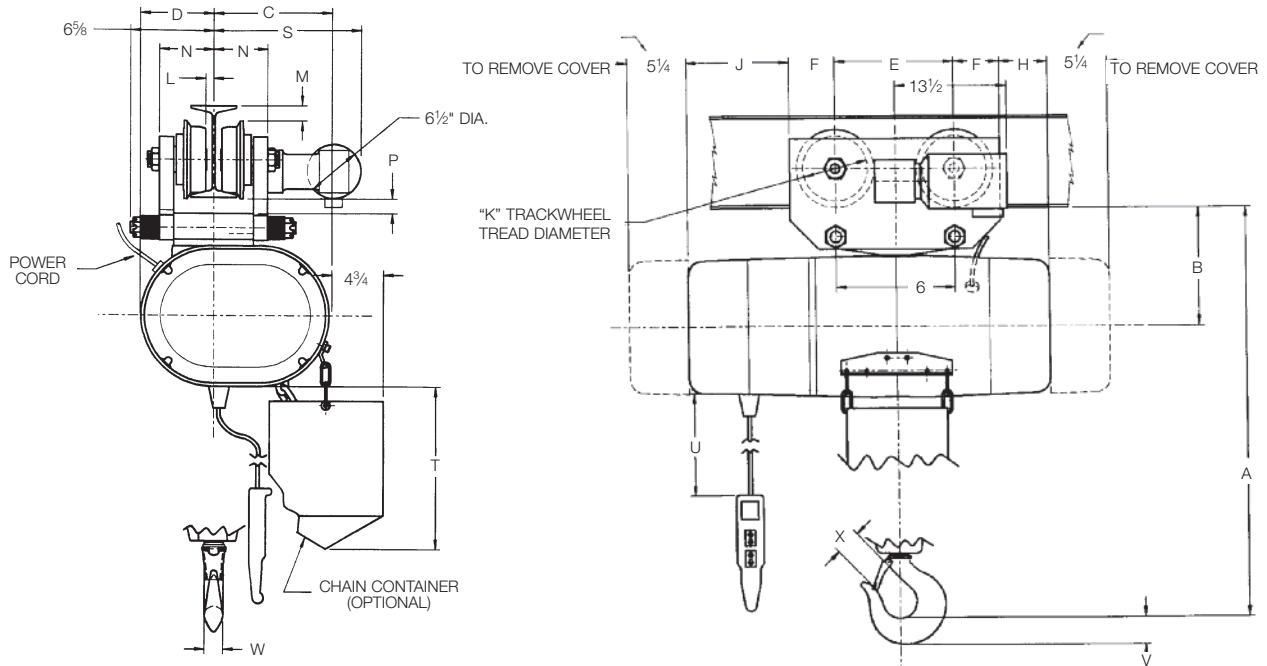

Clearance dimensions (in.)**

Dimensions	Double Reeved		Triple Reeved
	3 ton capacity	4 & 5 ton capacity	5-7½ ton capacity
A	33½	33¾	34⅝
B	10⅞	10⅞	10⅞
C	11⅞	11⅞	11⅞
D	5½	5½	5½
E	9⅞	12	12
F	3¼	4⅞	4⅞
H	5⅞	2⅞	2⅞
J	10½	7½	7½
K	4	6½	6½
L	⅝	⅝	⅝
M	2⅞	0	0
N	3⅝	3⅞	3⅞
P	⅜	⅞	⅞
S	11⅞	13⅞	13⅞
T (based on 10 ft. lift)	14⅞	14⅞	14⅞
U (based on 10 ft. lift)	6'- 3"	6'- 3"	6'- 3"
V	2¼	2¼	2¼
W	1⅝	1⅝	1⅝
X	2⅞	2⅞	2⅞
Minimum Radius Curve (ft.)	4	6	6
Standard Beam Flange Adj. Range (in.)	4.00-6.25	4.00-6.25	4.00-6.25
Trolley Speed (ft./min)			
Standard Single Speed	50	50	50

**Dimensions listed are for minimum size "S" beam.

