

CHESTER HOIST

Chester Electric Low Headroom Chain Hoists

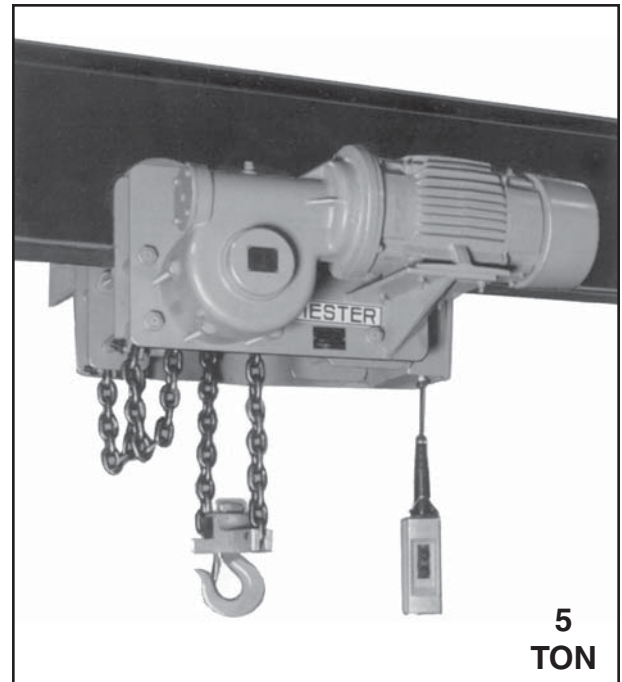
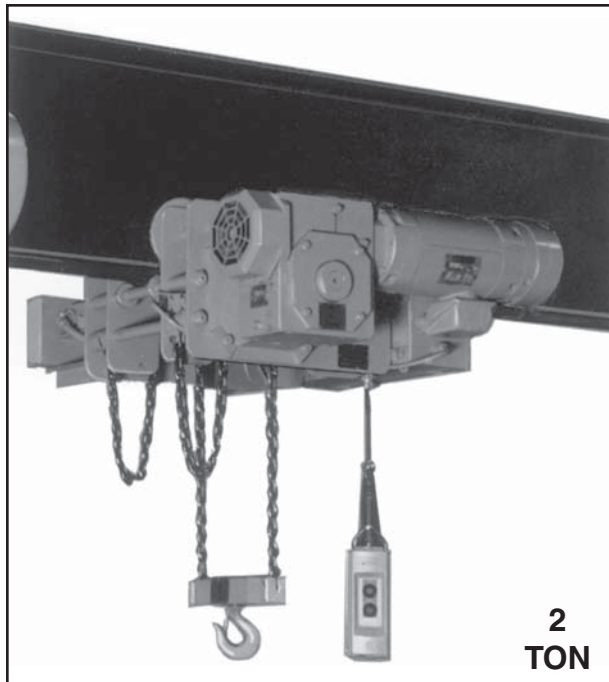

We offer a complete line of worm gear driven, electric, low headroom trolley hoists. These hoists are equipped with case hardened load chain and are available in models to lift and move loads from 1 to 24 tons. Choices of plain push/pull, hand-gearred or motorized trolley drives are available to meet a variety of applications.

- Manufactured in the U.S.A.
- 5 and 6 pocket load wheels – chain saver feature
- Durable self-locking worm drive transmission requiring little if any maintenance
- Sturdy steel construction
- Direct acting motor brake which sets automatically if power is interrupted
- Two precision bearings per trolley wheel minimizes traversing effort

CHESTER

ELECTRIC LOW HEADROOM CHAIN HOISTS



Chester Electric Low Headroom Chain Hoists are designed for those applications where headroom is limited. Engineered around proven designs, these hoists provide smooth, quiet, trouble-free operation in a variety of Class III hoisting applications. Each unit is built and tested in accordance with the nationally recognized safety standard for overhead hoists ANSI B30.16.

Standard units are furnished with 115 VAC pendant-type two-or four-button weather-resistant control station with push button drop four feet less than lift. Standard controls include, reversing contactors for hoist, control transformer (115 VAC) and terminal block in a NEMA-12 cabinet, supply voltage is 230/460 VAC, 3 phase, 60 Hz and each unit has redundant limit switches for both the upper and lower hook travel.

The Chester Electric Low Headroom Chain Hoist is not adjustable for varying beam sizes. Each unit is custom-built to fit the specific beam specified in the order. Beam size, height, flange width and curve radius are required for all orders.

FOR IMMEDIATE SERVICE – CALL CHESTER!

Catalog Number			Rated capacity in short tons	Standard lift in feet	†† Minimum radius curve	Minimum distance bottom of I-beam to hook in inches	Hoist Speed (FPM)	Motorized Trolley Speed (FPM)	Motor (H.P.) (RPM)	Net Weight Lbs.		
Plain	Hand Geared	Motorized								Plain	Hand Geared	Motorized
ELP-1	ELG-1	ELM-1	1	10	6'6"	7"	10	35	2@1800	440	470	480
ELP-1½	ELG-1½	ELM-1½	1½	10	6'6"	7"	10	35	2@1800	440	470	480
ELP-2	ELG-2	ELM-2	2	10	6'6"	7"	10	35	2@1800	440	470	480
ELP-3	ELG-3	ELM-3	3	10	6'6"	8"	5	35	2@1800	540	570	580
ELP-4	ELG-4	ELM-4	4	10	7'6"	8½"	5	35	2@1800	540	570	580
ELP-5	ELG-5	ELM-5	5	10	8'6"	9½"	7	35	4@1200	1280	1340	1310
ELP-6	ELG-6	ELM-6	6	10	8'6"	9½"	7	35	4@1200	1280	1340	1310
ELP-8	ELG-8	ELM-8	8	10	9'6"	12"	4	20	4@1200	1350	1480	1400
ELP-10	ELG-10	ELM-10	10	10	10'	12½"	3.5	20	4@1200	1730	1810	1780
ELP-12	ELG-12	ELM-12	12	10	†	12½"	3.5	20	4@1200	1730	1810	1780
ELP-16	ELG-16	ELM-16	16	10	†	14½"	2	20	4@1200	2300	2380	2350
ELP-20	ELG-20	ELM-20	20	10	†	18"	1.7	20	4@1200	2650	2810	2750
ELP-24	ELG-24	ELM-24	24	10	†	18"	1.7	20	4@1200	2650	2810	2750

† Straight track operation only recommended for these units. However curve radius must be specified on orders.

†† Curves less than minimum may be fitted by special construction. Consult factory.

ALL HEADROOM DIMENSIONS DETERMINED WHILE HOIST UNDER LOAD

CHESTER

ELECTRIC LOW HEADROOM CHAIN HOISTS

CLEARANCE DIMENSIONS

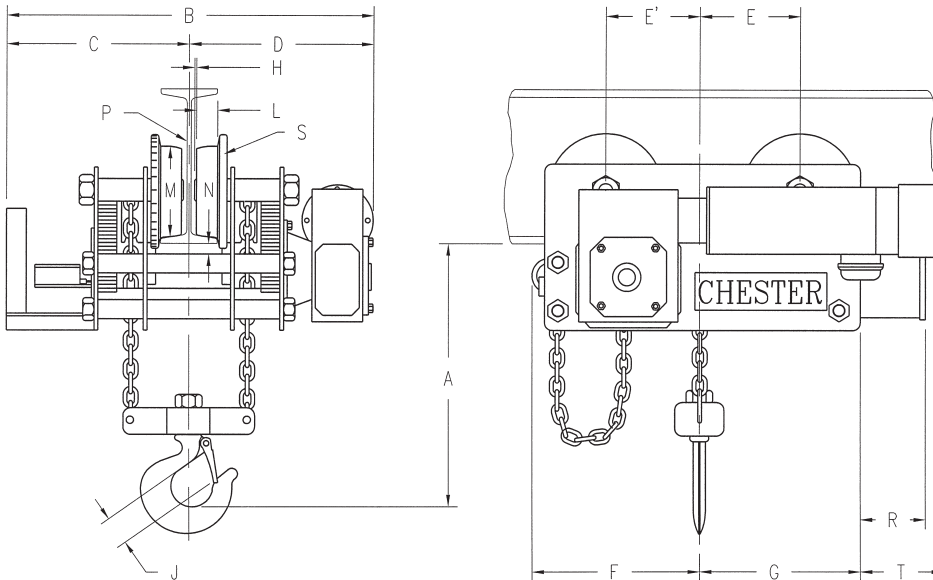

Minimum Radius Curve

CAPACITY	MINIMUM RADIUS CURVE
1 1/2 - 2 Ton	6' 6"
3 - 4 Ton	7' 6"
5 - 6 Ton	8' 6"
8 Ton	9' 6"
10 Ton	10' 0"

For over 10 Ton, straight track operation is recommended.

Curve radius must be specified on orders.

Curves less than minimum radius may be fitted upon application.

PLAIN OR GEARED

Capacity Tons	A	B	C	D	E	E'	F	G	H***
1	7"	33 ¹³ / ₁₆ "	16 ¹ / ₂ "	17 ⁵ / ₁₆ "	7 ³ / ₄ "	7 ³ / ₄ "	12"	10"	1 ¹ / ₁₆ "
1 1/2	7"	33 ¹³ / ₁₆ "	16 ¹ / ₂ "	17 ⁵ / ₁₆ "	7 ³ / ₄ "	7 ³ / ₄ "	12"	10"	1 ¹ / ₁₆ "
2	7"	33 ¹³ / ₁₆ "	16 ¹ / ₂ "	17 ⁵ / ₁₆ "	7 ³ / ₄ "	7 ³ / ₄ "	12"	10"	1 ¹ / ₁₆ "
3	8"	33 ¹³ / ₁₆ "	16 ¹ / ₂ "	17 ⁵ / ₁₆ "	9"	9"	14 ³ / ₄ "	13"	1 ¹ / ₄ "
4	8 ¹ / ₂ "	33 ¹³ / ₁₆ "	16 ¹ / ₂ "	17 ⁵ / ₁₆ "	9"	9"	14 ³ / ₄ "	13"	1 ¹ / ₄ "
5	9 ¹ / ₂ "	48 ¹³ / ₁₆ "	23 ¹ / ₂ "	25 ⁵ / ₁₆ "	7 ³ / ₈ "	7 ³ / ₈ "	13 ¹ / ₁₆ "	15 ¹ / ₁₆ "	1 ¹ / ₁₆ "
6	9 ¹ / ₂ "	48 ¹³ / ₁₆ "	23 ¹ / ₂ "	25 ⁵ / ₁₆ "	7 ³ / ₈ "	7 ³ / ₈ "	13 ¹ / ₁₆ "	15 ¹ / ₁₆ "	1 ¹ / ₁₆ "
8	12"	48 ¹³ / ₁₆ "	23 ¹ / ₂ "	25 ⁵ / ₁₆ "	8 ³ / ₈ "	8 ⁷ / ₈ "	14"	13 ¹ / ₂ "	3 ¹ / ₁₆ "
10	12 ¹ / ₂ "	48 ¹³ / ₁₆ "	23 ¹ / ₂ "	25 ⁵ / ₁₆ "	8 ¹ / ₂ "	9 ³ / ₄ "	15 ⁵ / ₈ "	14 ³ / ₈ "	3 ³ / ₈ "
12	12 ¹ / ₂ "	48 ¹³ / ₁₆ "	23 ¹ / ₂ "	25 ⁵ / ₁₆ "	8 ¹ / ₂ "	9 ³ / ₄ "	15 ⁵ / ₈ "	14 ³ / ₈ "	3 ³ / ₈ "
16	14 ¹ / ₂ "	52 ⁷ / ₈ "	25 ¹ / ₂ "	27 ³ / ₈ "	11 ⁷ / ₈ "	11 ⁷ / ₈ "	18 ⁵ / ₈ "	18 ⁵ / ₈ "	7 ¹ / ₁₆ "
20	18"	52 ⁷ / ₈ "	26 ¹ / ₂ "	27 ³ / ₈ "	12 ¹ / ₈ "	12 ³ / ₈ "	19 ¹ / ₄ "	19"	7 ¹ / ₁₆ "
24	18"	52 ⁷ / ₈ "	26 ¹ / ₂ "	27 ³ / ₈ "	12 ¹ / ₈ "	12 ³ / ₈ "	19 ¹ / ₄ "	19"	7 ¹ / ₁₆ "

Capacity Tons	J	L	M	N	P*	R	S	T**
1	15 ⁵ / ₃₂ "	1 ¹ / ₈ "	4 ¹ / ₂ "	1 ¹ / ₂ "	6" I @ 12.5#	6 ¹ / ₂ "	6"	8 ⁷ / ₈ "
1 1/2	15 ⁵ / ₃₂ "	1 ¹ / ₈ "	4 ¹ / ₂ "	1 ¹ / ₂ "	6" I @ 12.5#	6 ¹ / ₂ "	6"	8 ⁷ / ₈ "
2	15 ⁵ / ₃₂ "	1 ¹ / ₈ "	4 ¹ / ₂ "	1 ¹ / ₂ "	6" I @ 12.5#	6 ¹ / ₂ "	6"	8 ⁷ / ₈ "
3	11 ¹³ / ₃₂ "	1 ¹¹ / ₃₂ "	6 ³ / ₈ "	5 ⁵ / ₈ "	8" I @ 18.4#	6 ¹ / ₂ "	8"	4 ¹ / ₈ "
4	11 ¹¹ / ₁₆ "	1 ¹¹ / ₃₂ "	6 ³ / ₈ "	5 ⁵ / ₈ "	8" I @ 18.4#	6 ¹ / ₂ "	8"	4 ¹ / ₈ "
5	11 ¹¹ / ₁₆ "	1 ¹³ / ₃₂ "	7 ³ / ₁₆ "	5 ⁵ / ₈ "	10" I @ 25.4#	6 ¹ / ₂ "	9"	10 ¹ / ₄ "
6	11 ¹¹ / ₁₆ "	1 ¹³ / ₃₂ "	7 ³ / ₁₆ "	5 ⁵ / ₈ "	10" I @ 25.4#	6 ¹ / ₂ "	9"	10 ¹ / ₄ "
8	27 ³ / ₃₂ "	1 ¹¹ / ₁₆ "	8 ¹ / ₄ "	9 ⁹ / ₁₆ "	10" I @ 25.4#	6 ¹ / ₂ "	10"	10 ¹ / ₂ "
10	2 ¹ / ₄ "	1 ³ / ₄ "	9 ³ / ₄ "	3 ³ / ₄ "	12" I @ 31.8#	6 ¹ / ₂ "	11 ¹¹ / ₁₆ "	8 ³ / ₈ "
12	2 ¹ / ₄ "	1 ³ / ₄ "	9 ³ / ₄ "	3 ³ / ₄ "	12" I @ 31.8#	6 ¹ / ₂ "	11 ¹¹ / ₁₆ "	8 ³ / ₈ "
16	3"	2"	11 ³ / ₄ "	3 ³ / ₄ "	15" I @ 42.9#	6 ¹ / ₂ "	13 ¹ / ₂ "	1 ³ / ₄ "
20	3 ⁵ / ₈ "	2"	11 ³ / ₄ "	3 ³ / ₄ "	18" I @ 54.7#	6 ¹ / ₂ "	13 ¹ / ₂ "	7 ⁷ / ₈ "
24	3 ⁵ / ₈ "	2"	11 ³ / ₄ "	3 ³ / ₄ "	18" I @ 54.7#	6 ¹ / ₂ "	13 ¹ / ₂ "	7 ⁷ / ₈ "

All Dimensions are in inches.

P* – Min. Std. I-beam for Proper Wheel Running Clearance Only. Customer must verify their beam is adequate for the applied Loading. H*** – From the Face of Wheel to the End of the Axle.

T** – For Std. Motor and Brake Only. Hoists are designed for H-3 duty.