



## RLB TWIN HOIST ROTATING LIFTING BEAM

A specially designed lifting and rotating beam using two cranes or two hoists to horizontally rotate a load. A position locking pin holds the load rotation at a designated position. Available with motorized rotation.

### PRODUCT FEATURES

- Wide range of sizes and capacities available.
- Maximum 20 feet (upper and lower) beam length.
- Complies with ASME standards.

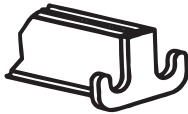
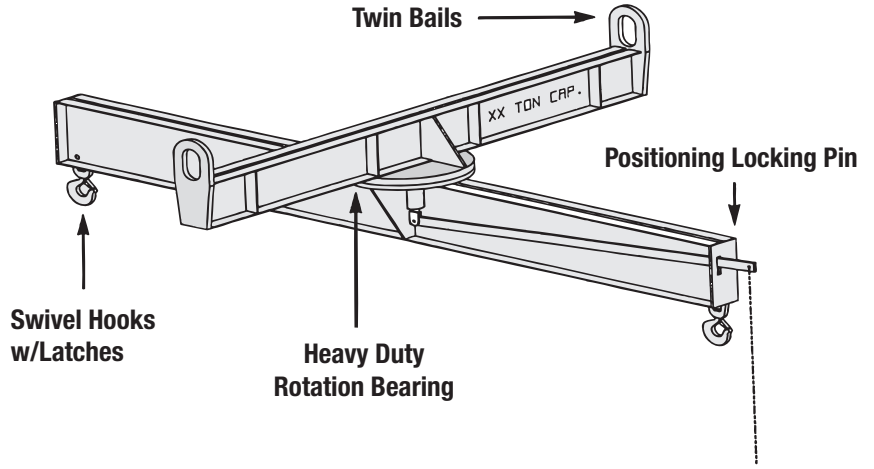

**OPTION A**  
**Twin Hooks**  
Used in conjunction with basket hitch slings.



**OPTION B**  
**J Hooks**  
Generally required to lift paper rolls or similar application. Use Paper Roll Lifters Application Evaluation on page 57.

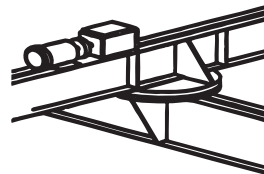

**OPTION C**  
**Motorized Rotation**  
Allows remote positioning of a load.



**OPTION D**  
**Lower Head Room Bails**  
Utilized when headroom must be held to a minimum. Crane hook data must be supplied, see page 56.

## CCB CHLORINE CYLINDER LIFTING BEAM

Designed to efficiently handle standard chlorine gas cylinders. Standard size determined by the Chlorine Institute is 80-3/4" to 82-1/4" in length. Special low headroom modification is available.

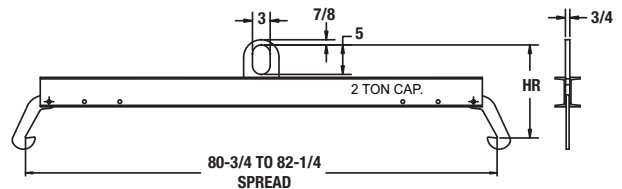

Note: All dimensions shown in inches.

### SPECIFICATIONS

Model Number	Capacity (tons)	HR Headroom (in.)	Weight (lbs.)
CCB2165	2	16-1/2 - 15-1/2	105