

## VCL VERTICAL COIL LIFTER

### PRODUCT FEATURES

- Efficient handling of vertically stacked coils.
- Leg positioning handle is easy to operate and has a positive locking feature.
- Handles any size coil I.D. from 16" to 20".
- Complies with ASME standards.

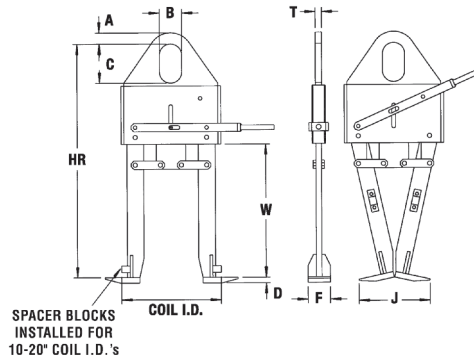

Spacer Blocks Installed for 16-18" coil I.D.'s. See Instruction Manual for details.

### SPECIFICATIONS

Model Number	Capacity (tons)	Dimensions (inches)											Weight (lbs.)
		Coil I.D.		Coil Width W	HR Headroom	Bail Dimensions				Foot Dimensions			
		Min.	Max.			A	B	C	T	F	D	J	
VCL100020	1/2	16	20	20	36	1-1/4	3	5	5/8	4	3/4	13	110
VCL1520	1-1/2	16	20	24	36	1-1/2	3	5	5/8	4	3/4	13	125
VCL320	3	16	20	24	40	1-1/2	3	5	3/4	5	3/4	13-1/2	180
VCL520	5	16	20	30	49	2	4	7	1	6	3/4	14-1/4	195

Other sizes available, consult factory.

COIL LIFTERS & UPENDERS

## ECL EXTENDED WIDTH VERTICAL COIL LIFTER

### PRODUCT FEATURES

- Handles any size coil I.D. from 16" to 24".
- Lifter legs automatically adjust to coil I.D. being lifted.
- Has higher capacity range than standard lifter.
- Unique design minimizes dunnage required between coils.
- Complies with ASME standards.

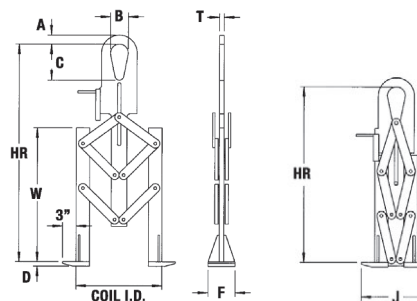

### SPECIFICATIONS

Model Number	Capacity (tons)	Dimensions (inches)												Weight (lbs.)
		Coil I.D.		Coil Width W	HR Headroom		Bail Dimensions				Foot Dimensions			
		Min.	Max.		Open	Closed	A	B	C	T	F	D	J	
ECL100024	1/2	16	24	20	36	30-7/8	1-1/4	3	5	5/8	5	1/2	14-1/2	90
ECL2524	2-1/2	16	24	24	44	37-1/2	1-1/2	3	5	3/4	5	3/4	15-1/2	125
ECL524	5	16	24	30	47	40-3/8	2	4	7	1	6	1	15-1/2	170
ECL7524	7-1/2	16	24	30	47	40-3/8	2	4	8	1	6	1	15-1/2	170

Other sizes available, consult factory.