

CM[®]

Hurricane
HAND CHAIN HOIST

360°



**APPROACH FROM
A NEW ANGLE**

 **TAYLOR**
MATERIAL HANDLING & CONVEYOR
Phone: 419-867-3560
www.taylormhc.com

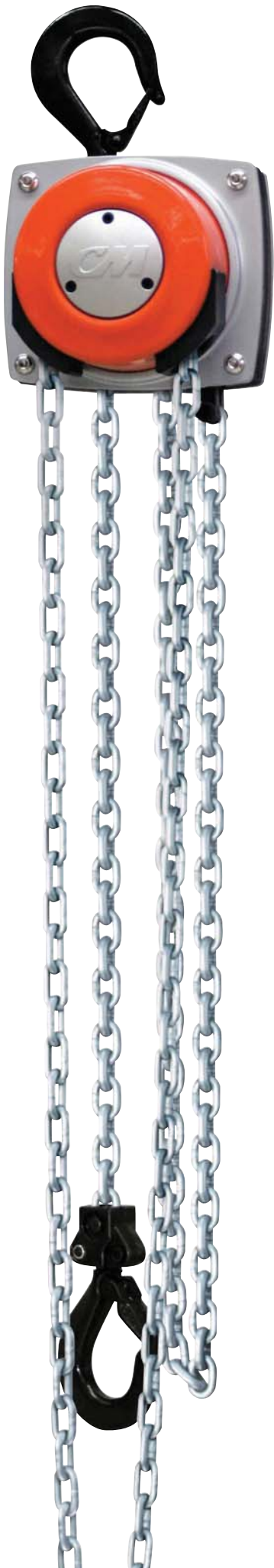

Hurricane

HAND CHAIN HOIST

360°

1/2 to 10 tons Capacities

For the ultimate flexibility in a hand chain hoist, the CM Hurricane 360° is the choice for a wide range of applications. The patented hand chain cover rotates a full 360 degrees to allow loads to be lifted, pulled, or positioned from virtually any angle. In addition to providing maximum versatility, this unit offers a convenient way to maneuver loads without standing under the load. The Hurricane 360° allows workers to view hand chain hoists in a whole new light and provides a tool for addressing unique jobs in a broad range of environments.

TRUSTED RELIABILITY

Braking power of our Weston-Style Braking System which provides positive load control & reliable performance. Minimal maintenance and easily disassembled with no special tools.

SAFETY

Standard Load Limiter for simple, automatic overload protection.

BUILT TO LAST

All internal gears and pinions are heat treated steel for high strength and long life. Precision 4-Pocket Liftwheel and Chain Guide provides better chain fit and alignment which reduces wear and increases chain life.

RUGGED TOUGHNESS

Powder Coated Finish for corrosion protection. Alloy hardened Steel Load Chain assures high strength and long wear life.

MEETS ASME B30.16 & EUROPEAN CE STANDARD

LIFETIME WARRANTY



APPROACH FROM A NEW ANGLE APPROACH FROM ANY ANGLE

The Hurricane 360° is ideal when working:

- **in tight spaces** where the rigid handle of a lever hoist would be difficult to maneuver and operate.
- **above the load** being lifted.
- **on a drifting application** where the hand chain angle adjusts throughout the operation.
- with large loads to allow the operator to be **a safe distance** away.

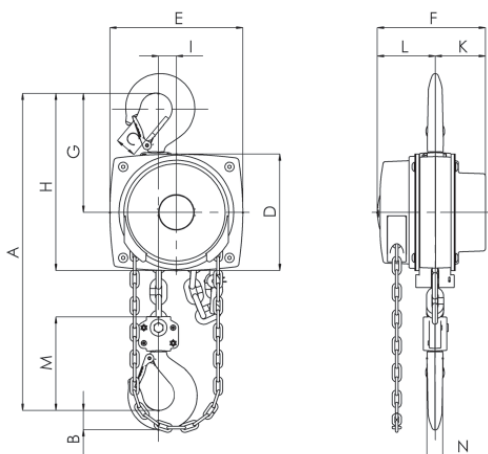

Hurricane 360° LESS CHAIN

Product Code	Load Rating (Tons)
5632A	1/2
5633A	1
5634A	2
5638A	3
5642A	5
5646A	10

SPECIFICATIONS

Product Code	Load Rating TONS (kg)	Lift		Net Weight LBS.	Hand Chain Pull to Lift Rated Load LBS. (kg)	Hand Chain Overhauled to Lift Foot FT. (m)	Dimensions in inches (mm)												
		ft.	m				A	B	C	D	E	F	G	H	I	K	L	M	N
5623A	1/2 (500)	10	3	23	44 (20)	30 (9.1)	11.811 (300)	0.669 (17)	0.945 (24)	5.236 (133)	5.827 (148)	5.827 (148)	5.472 (139)	8.110 (206)	0.945 (24)	2.402 (61)	3.425 (87)	4.331 (110)	0.551 (14)
5624A		15	4.5	28															
5625A 5651A		20 30	6 9	33 43															
5626A	1 (1000)	10	3	26	54 (24)	49 (14.9)	13.189 (335)	0.866 (22)	1.142 (29)	6.142 (156)	6.890 (175)	6.575 (167)	6.457 (164)	9.528 (242)	0.945 (24)	2.756 (70)	3.819 (97)	4.921 (125)	0.748 (19)
5627A		15	4.5	33															
5628A 5653A		20 30	6 9	41 58															
5629A	2 (2000)	10	3	45	74 (34)	71 (21.6)	15.551 (395)	1.181 (30)	1.378 (35)	7.165 (182)	7.992 (203)	7.638 (194)	7.559 (192)	11.142 (283)	1.220 (31)	3.268 (83)	4.370 (111)	6.142 (156)	0.866 (22)
5630A		15	4.5	48															
5631A		20	6	51															
5635A	3 (3000)	10	3	68	92 (42)	87 (26)	20.472 (520)	1.496 (38)	1.575 (40)	8.661 (220)	9.843 (250)	8.622 (219)	8.858 (225)	13.189 (335)	1.339 (34)	3.740 (95)	4.882 (124)	7.008 (178)	1.181 (30)
5636A		15	4.5	79															
5637A		20	6	90															
5639A	5 (5000)	10	3	122	76 (34)	174 (53)	25.748 (654)	1.772 (45)	1.850 (47)	8.661 (220)	9.843 (250)	8.622 (219)	9.528 (242)	13.858 (352)	0.827 (21)	3.740 (95)	4.882 (124)	11.220 (285)	1.457 (37)
5640A		15	4.5	142															
5641A		20	6	162															
5643A	10 (10000)	10	3	210	102 (46)	261 (79.3)	32.480 (825)	2.677 (68)	2.677 (68)	8.661 (220)	15.079 (383)	8.622 (219)	12.835 (326)	17.165 (436)	5.354 (136)	3.740 (95)	4.882 (124)	15.787 (401)	1.969 (50)
5644A		15	4.5	240															
5645A		20	6	270															



THE POWER OF INTELLIGENT LIFTING

Columbus McKinnon is one of the most respected and well-known names in the material handling industry. We combine two different yet complimentary areas of expertise – rigging products and hoists – to develop complete floor-to-ceiling lifting systems for even the most unique material handling applications.

Columbus McKinnon designs and manufactures a large portfolio of durable and reliable products for a variety of industries. Our portfolio includes powered and manual hoists, rigging products, below-the-hook attachments, cranes, enclosed track systems and specially engineered products.

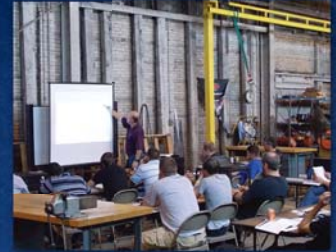

KNOW HOW. KNOW WHY. BE SAFE. GET TRAINED.



Not only is Columbus McKinnon a leader in material handling products, we are also a global leader in providing expertise and training on the proper use and inspection of rigging and overhead lifting equipment. With a range of comprehensive programs and seminars conducted at venues throughout North America, including our hands-on training centers and private companies, our courses include:

- Hoist Maintenance
- Crane & Hoist Inspection
- Crane Operator Training
- Safe Hoisting
- Load Securement
- Rigging
- Rigging Gear Inspection

One of our newest programs, **CMCO University™**, is a three-day course designed to give attendees an intimate knowledge of our products, the information they'll need to select the right product for the application, and the tools to win in the marketplace.

Classes are available at our state-of-the-art, hands-on training centers, including the **Niagara Training Center** and the **Hoist & Rigging Training Center of Excellence in the Center for Occupational Health and Automobile Manufacturing (COHAM) lab at The Ohio State University.**

Rely on Columbus McKinnon for the products and expertise you need to keep your workforce productive and safe.



USA: Ph: (800) 888.0985 • (716) 689.5400 • Fax: (716) 689.5644

CANADA: Ph: (877) 264.6478 • Fax: (877) 264.6477

