

CM[®]

SHOPSTAR[®]

ELECTRIC CHAIN HOIST

CAPACITIES	LIFT	SPEEDS	VOLTAGES
250 to 1000 lbs.	10 feet standard	6 to 40 feet/minute	1-phase & 3-phase available

The CM ShopStar electric chain hoist is built for rugged industrial and commercial use. This durable hoist features high H4 duty cycles and a compact design ideal for use at workstations and production lines. Standard overload device protects the hoist, operator and surrounding structure from damaging overloads.

H4 DUTY CYCLE
300 motor starts per hour

RUGGED & DURABLE
Thermally protected hoist motor. Cast aluminum alloy hoist frame with durable epoxy powder coat finish.

LOW MAINTENANCE
Gear train lifetime lubricated with non-oxidizing grease. Totally enclosed hoist frame protects motor from environmental contamination.

DUAL BRAKING SYSTEM
D.C. brake plus regenerative

LONG CHAIN LIFE
Durable CM Hoist Alloy Load Chain. 10-pocket, oblique-lay lift wheel for longer chain wear.

TRUE VERTICAL LIFT

NEMA 4 INDUSTRIAL-RATED CONTROL STATION

THE INDUSTRY'S BEST LIFETIME WARRANTY

OPTIONAL SWIVEL HOOK SUSPENSION



Swivel Hook with latch

Swivel Hook with Latchlok[®] latch

NOW AVAILABLE WITH OPTIONAL SWIVEL HOOK SUSPENSION

Providing versatility and flexibility, hook rotates 360° for easy attachment and positioning.



CLEARANCE DIMENSIONS (IN.)

Reeving	A	B	C	D
Single	11-1/16	3	2-15/16	3-7/8
Double	11-15/16	3-9/16	2-3/8	5-3/4

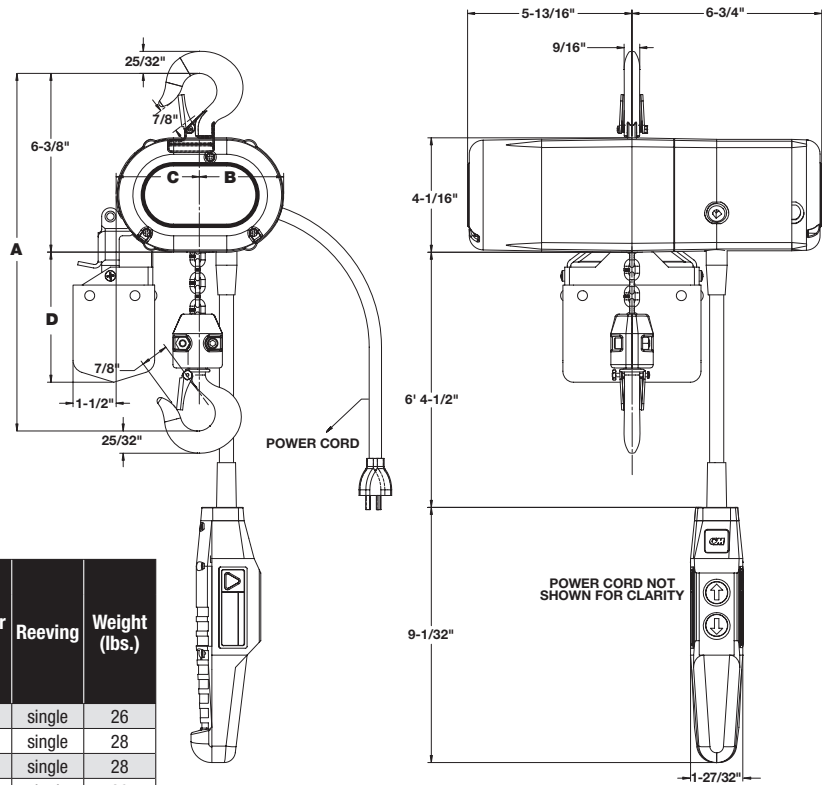

SPECIFICATIONS

Capacity (lbs.)	Product Code				Lift (ft.)	Lifting Speed (FPM)	Motor Hp	Reeving	Weight (lbs.)
	115-1-60 Contactor in Push Button Station	115-1-60 Contactor in Hoist	230-3-60	460-3-60					
250	2070	-	-	-	10	16	1/6	single	26
	-	2069	2071	2072	10	16	1/6	single	28
	-	-	2076	2077	10	24	1/6	single	28
	-	-	2081	2082	10	40	1/6	single	28
300	2000	-	-	-	10	16	1/6	single	26
	-	2047	2026	2029	10	16	1/6	single	28
	2002	-	-	-	15	16	1/6	single	28
	-	-	2027	2030	15	16	1/6	single	29
	2004	-	-	-	20	16	1/6	single	28
	-	-	2028	2031	20	16	1/6	single	30
	-	-	2086	2087	10	24	1/6	single	28
500	-	-	2074	2075	10	40	1/6	single	28
	2095	-	-	-	10	8	1/6	double	32
	-	2094	2096	2097	10	8	1/6	double	34
	2090	-	-	-	10	12	1/6	single	26
	-	2089	2091	2092	10	12	1/6	single	28
	-	-	2080	2084	10	16	1/6	single	28
	-	-	2101	2102	10	20	1/6	double	34
	-	-	2099	2100	10	24	1/6	single	28
600	2001	-	-	-	10	8	1/6	double	32
	-	2048	2035	2038	10	8	1/6	double	34
	2003	-	-	-	15	8	1/6	double	35
	-	-	2036	2039	15	8	1/6	double	37
	2005	-	-	-	20	8	1/6	double	37
	-	-	2037	2040	20	8	1/6	double	39
	-	-	2106	2107	10	12	1/6	double	34
	-	-	2105	2114	10	20	1/6	double	34
1000	2110	-	-	-	10	6	1/6	double	32
	-	2109	2111	2112	10	6	1/6	double	34
	-	-	2116	2117	10	8	1/6	double	32
	-	-	2119	2121	10	12	1/6	double	32

SWIVEL HOOKS (OPTIONAL)

Product Code	Description
10001130K	Shopstar/Prostar Swivel Latch-Type Hook Suspension
10001297K	Shopstar/Prostar Swivel Latchlok Hook Suspension



CHAIN CONTAINERS (OPTIONAL)

Product Code	Maximum Length of Lift (ft.)		Weight (lbs.)
	Single Reeved	Double Reeved	
2063	10	5	1.0
2064	20	10	1.4
2065	40	20	1.4
2066	80	40	1.4
2067	120	60	2.2



Phone (800) 888.0985 • Fax: (716) 689.5644 • www.cmworks.com

