

CHESTER HOIST

Performance Plus Flexibility



ZEPHYR
Hook Suspended Hoists

SPECIFICATIONS & DIMENSIONS

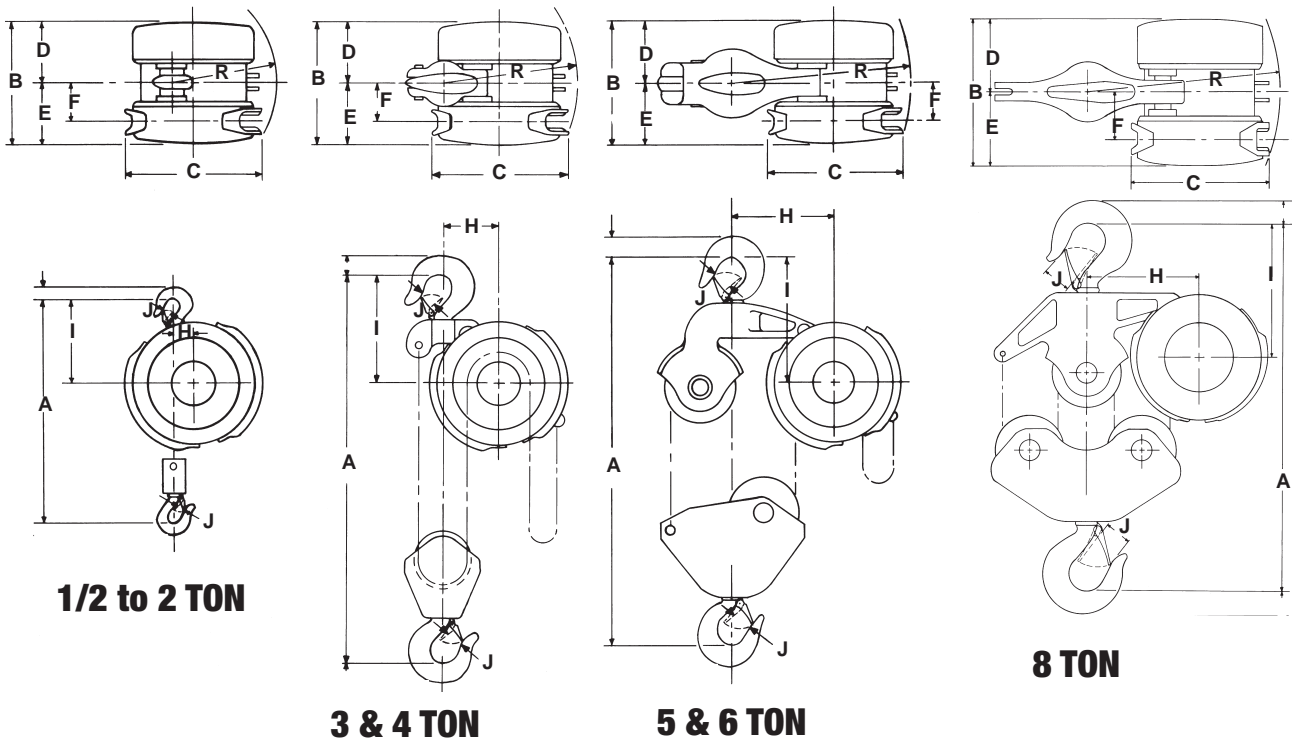

SINGLE LOAD CHAIN - 1/2 to 2 TON

A	B	C	D	E	F	H	I	J	R	TONS
12 1/8	8 1/2	8 3/4	4 1/4	4 1/4	3	1 3/8	6 7/16	1	7	1/2
12 1/8	8 1/2	8 3/4	4 1/4	4 1/4	3	1 3/8	6 7/16	1	7	1
15 7/8	10	11 1/2	5	5	3 1/4	1 3/4	7 5/8	1 1/8	8 1/2	1 1/2
15 7/8	10	11 1/2	5	5	3 1/4	1 3/4	7 5/8	1 1/8	8 1/2	2

DOUBLE LOAD CHAIN - 3 & 4 TON

A	B	C	D	E	F	H	I	J	R	TONS
23 1/2	10	11 1/2	5	5	3 1/4	4 7/8	9 1/8	1 11/32	11 1/2	3
24 1/2	10	11 1/2	5	5	3 1/4	4 7/8	9 5/8	1 11/16	11 1/2	4

TRIPLE LOAD CHAIN - 5 & 6 TON 4 STRANDS LOAD CHAIN - 8 TON

A	B	C	D	E	F	H	I	J	R	TONS
25 1/2	10	11 1/2	5	5	3 1/4	6 3/8	10 1/2	1 11/16	13 1/2	5
25 1/2	10	11 1/2	5	5	3 1/4	6 3/8	10 1/2	1 11/16	13 1/2	6
26 3/4	10	11 1/2	5	5	3 1/4	8 1/2	11	2 1/16	14	8

ZEPHYR

SPECIFICATIONS & DIMENSIONS

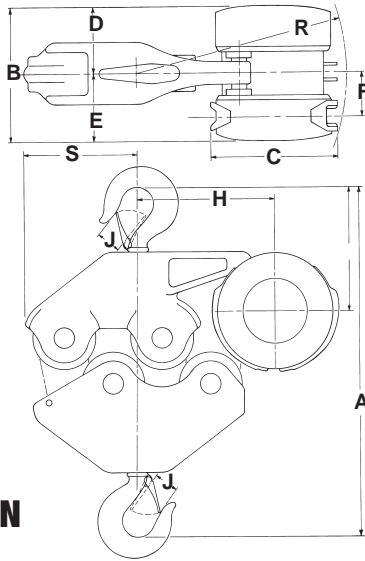

10 TON

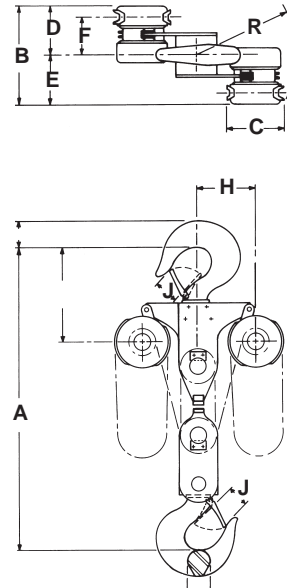

12 to 25 TON

10 to 25 TON

A	B	C	D	E	F	H	I	J	R	S	TONS
30 3/4	10	11 1/2	5	5	3 1/4	10 1/4	10 5/8	2 1/4	17	9 1/4	10
49 5/8	14 5/8	11 1/2	7 5/16	7 5/16	5 9/16	11 1/8	13 9/16	3	18 1/2	-	12
53 1/2	16 3/8	11 1/2	8 3/16	8 3/16	6 7/16	11 1/8	15 1/8	3 5/8	18 3/4	-	16
56 3/8	18 1/4	11 1/2	9 1/8	9 1/8	7 3/8	11 1/8	15 1/8	3 5/8	19 3/16	-	20
56 3/8	20 1/8	11 1/2	10 1/16	10 1/16	8 5/16	11 1/8	15 1/8	3 5/8	19 11/16	-	25

SPECIFICATIONS

Catalog Number	Capacity Tons	Standard Lift	Minimum Distance Between Hooks in Inches	Chain Pull in Pounds to Lift Full load	Feet of Chain Overhauled to Lift One Foot	Strands of Chain		Length of Chain		Weight in Pounds	
						Load	Hand	Load	Hand	Net	Gross
130 1/2	1/2	8'	12 1/8	31	33	1	2	9' - 0"	14' - 0"	44	46
130 - 1	1	8'	12 1/8	62	33	1	2	9' - 0"	14' - 0"	46	48
130 - 1 1/2	1 1/2	8'	15 7/8	57	58	1	2	9' - 4"	14' - 6"	85	88
130 - 2	2	8'	15 7/8	76	58	1	2	9' - 4"	14' - 6"	85	88
130 - 3	3	8'	23 1/2	60	116	2	2	18' - 6"	15' - 6"	122	140
130 - 4	4	8'	24 1/2	79	116	2	2	18' - 6"	15' - 6"	130	144
130 - 5	5	8'	25 1/2	65	174	3	2	27' - 6"	15' - 6"	184	208
130 - 6	6	8'	25 1/2	78	174	3	2	27' - 6"	15' - 6"	184	208
130 - 8	8	8'	26 3/4	81	232	4	2	36' - 0"	16' - 0"	245	283
130 - 10	10	8'	30 3/4	84	290	5	2	45' - 0"	16' - 6"	310	355
130 - 12	12	8'	49 5/8	*782	*174	6	4	67' - 0"	(2)19' - 0"	660	720
130 - 16	16	8'	53 1/2	*81(2)	*232	8	4	84' - 0"	(2)19' - 0"	825	900
130 - 20	20	8'	56 3/8	*85(2)	*290	10	4	101' - 0"	(2)20' - 0"	1050	1130
130 - 25	25	8'	56 3/8	*93(2)	*348	12	4	121' - 0"	(2)20' - 0"	1070	1160

* On each hand chain. 12 Ton & up have two hand chains.

CLEVIS CONNECTED HOIST WITH TROLLEY - plain and geared trolley

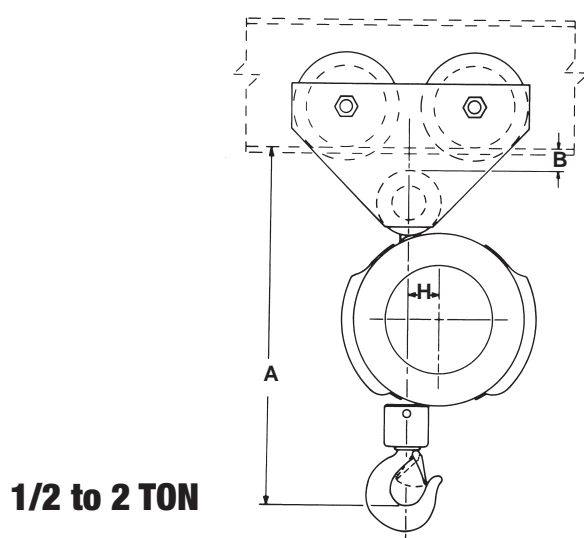

1/2 to 2 TON

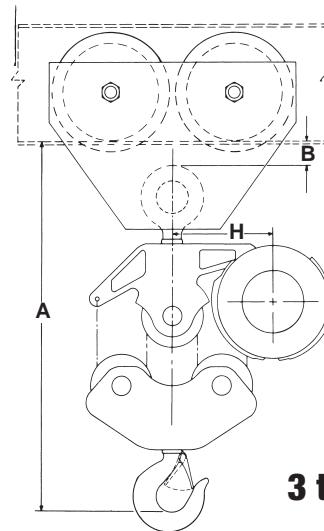

3 to 10 TON

Capacity in Tons	A	B	C
1/2	13 5/8	3/4	1 3/8
1	14 3/8	1 3/8	1 3/8
1 1/2	18 5/16	1 7/16	1 3/4
2	18 5/16	1 7/16	1 3/4
3	26 1/4	1 1/2	4 7/8
4	27 1/8	1 3/8	4 7/8
5	28 5/8	1 7/8	6 3/8
6	28 5/8	1 7/8	6 3/8
8	30 7/16	1 15/16	8 1/2
10	34 13/16	2 9/32	10 1/4

TROLLEY MUST BE ORDERED SEPARATELY

Clevis Connected hoist and trolley may be specified where headroom prohibits standard trolley suspension, or to prevent casual removal of hoist from trolley. Offers headroom advantage, retains rock-and-swivel flexibility of standard trolley suspension.

Any Zephyr hoist may be converted to Clevis Connected by removing suspension hook, replacing with clevis, and removing suspension strap of trolley. Conversion is completed by hanging clevis on trolley equalizing pin, and re-assembling.

Catalog Number	Capacity in Tons	Standard Lift	Minimum Headroom with Trolley	Adjustable for Standard I-Beam	Chain Pull to Lift Load One Foot	Chain Overhaul to lift load One Foot	Net Wt. Lbs. with Trolley	
							Plain	Generated
135 - 1/2	1/2	8'	13 7/16"	4 to 12"	31 lbs.	33 ft.	80	-
135 - 1	1	8'	14 3/16"	5 to 12"	62 lbs.	33 ft.	96	162
135 - 1 1/2	1 1/2	8'	18 1/16"	6 to 18"	57 lbs.	58 ft.	167	196
135 - 2	2	8'	18 1/16"	6 to 18"	76 lbs.	58 ft.	167	196
135 - 3	3	8'	26"	8 to 18"	60 lbs.	116 ft.	284	328
135 - 4	4	8'	26 7/8"	8 to 24"	79 lbs.	116 ft.	323	384
135 - 5	5	8'	28 5/16"	10 to 24"	65 lbs.	174 ft.	480	555
135 - 6	6	8'	28 5/16"	10 to 24"	78 lbs.	174 ft.	480	605
135 - 8	8	8'	30 1/8"	10 to 24"	81 lbs.	232 ft.	560	646
135 - 10	10	8'	34 "	10 to 24"	84 lbs.	290 ft.	785	860

ZEPHYR TWIN HOOK HOISTS

Available with hooks up to 16 feet between centers and extra length lifts as needed. The Twin Hook Hoist drives two separate load chains simultaneously from a single hand chain. Long and bulky loads can be more easily and evenly lifted with the Twin Hook Hoist. It handles such unwieldy pieces as tubes, frames, towers, drying and storage racks, auto and truck bodies, vats and tanks. Suspension hooks can be hung from trolleys or fixed positions.

STANDARD EXT. HOOK CENTER 3 FEET

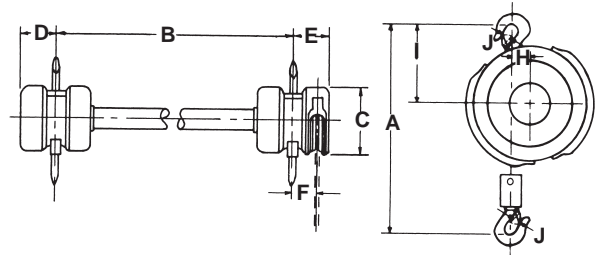

Catalog Number	Capacity	STD. Lift Feet	H.C. Overhauled Feet	H.C. Pull Lbs.	Net Wt.
133 - 1/2	1/2	8	33	35	106
133 - 1	1	8	33	70	162
133 - 1 1/2	1 1/2	8	58	64	287
133 - 2	2	8	58	83	412
133 - 3	3	8	116	66	535
133 - 4	4	8	116	86	592
133 - 5	5	8	174	71	715
133 - 6	6	8	174	86	715

A	B	C	D	E	F	H	I	J	TONS
12 1/8	36 Std.	7 1/4	4 1/4	4 1/4	3	1 3/8	5 7/8	1	1/2
12 1/4	36 Std.	7 1/4	4 1/4	4 1/4	3	1 3/8	5 7/8	1	1
15 7/8	36 Std.	9 1/4	5	5	3 1/4	1 3/4	8 1/8	1 1/8	1 1/2
15 7/8	36 Std.	9 3/4	5	5	3 1/4	1 3/4	8 1/8	1 1/8	2
23 1/2	36 Std.	9 3/4	5	5	3 1/4	4 7/8	9 1/8	1 11/32	3
24 1/2	36 Std.	9 3/4	5	5	3 1/4	4 7/8	9 5/8	1 11/16	4
25 1/2	36 Std.	9 3/4	5	5	3 1/4	6 3/8	11 1/2	1 11/16	5
25 1/2	36 Std.	9 3/4	5	5	3 1/4	6 3/8	11 1/2	1 11/16	6

Center baring required for shafts over 10 ft. Capacities beyond 6 Ton contact factory

ZEPHYR EXTENDED HANDWHEEL HOISTS

The Extended Hand Wheel Hoist allows the operator to stand at a distance from the load. Handling materials from a distance, or work whose surface must be protected from scratching by the hand chain, or large flat or bulky loads, are some of the practical applications. Suspension may be from fixed supports or on trolleys. Larger capacities: prices and information on request.

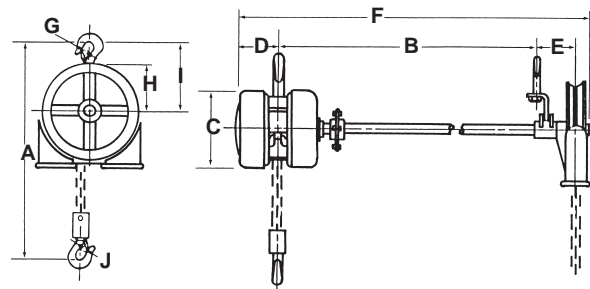

STANDARD HANDWHEEL EXT. 3 FEET

Catalog Number	Capacity	STD. Lift	Max. Ext.	Net Wt.
134 - 1/2	1/2	8	10'	78
134 - 1	1	8	10'	84
134 - 1 1/2	1 1/2	8	10'	115
134 - 2	2	8	10'	125

A	B	C	D	E	F	G	H	J	I	TONS
12 1/8	29 7/16	7 1/4	4 1/4	6 9/16	41 7/16	1	4 21/32	6 7/16	1	1/2
12 1/4	29 7/16	7 1/4	4 1/4	6 9/16	41 7/16	1	4 21/32	6 7/16	1	1
15 7/8	29 1/2	9 3/4	5	6 1/2	42 1/4	1	5 21/32	7 5/8	1 1/8	1 1/2
15 7/8	29 1/2	9 3/4	5	6 1/2	42 1/4	1	5 21/32	7 5/8	1 1/8	2

Capacities beyond 2 Ton contact factory

CHESTER ZEPHYR hoists are designed, built and tested to rigid specifications of quality and performance, to exceed standards common to the hoist industry.

The Chester Zephyr is a thoroughly engineered hoist from every standpoint. It has been made light in weight, compact and sturdy enough to serve as a rigger's hoist. Its simplicity of design makes it easy to service and maintain, insures long trouble-free periods of service. It is a stronger, more durable hoist because its fully enclosed construction makes it more shock resistant and impervious to practically any normal operating condition. Outdoors or in, the Zephyr hoist can withstand weather extremes.

Compactly constructed, the Zephyr is adaptable to many closequarter operations. The Zephyr requires only a minimum of headroom. Combined with its lightweight feature and with its adaptability to a wide variety of industrial operating conditions, the Chester Zephyr stands out as a versatile piece of material handling equipment.

It will do lifting and lowering efficiently and quickly. It will provide superior service through many years of operation and can be an important factor in lessening work fatigue, raising morale, reducing handling costs and time, and stepping up plant efficiency.

ALL SUSPENSION MEMBERS ARE STEEL

WARNING

Overloading and improper use can result in injury.

To avoid injury:

- Do not exceed working load limit, load rating or capacity.
- Do not use to lift people or loads over people.
- Use only alloy chain and attachments for overhead lifting.
- Read and follow all instructions.
- This equipment for manual operation only.

Z400-99

Bulletin A

2.5 MU © 2009 Columbus McKinnon

MECHANICALLY ENCLOSED Heavy steel housings keep out most foreign material, protecting precisionmachined working parts.

GREASE TIGHT-ENCLOSED Complete enclosure, sealed construction keeps lubrication in, making the Chester Zephyr a lifetime-lubricated hoist under normal conditions. No protruding parts, resists snagging.

SHOCK RESISTANT Heavy gauge steel in the stamped covers, two rolled steel sections in the frame, and use of strong alloy steels in suspension members make the Zephyr a sturdy hoist.

EASIER HANDLING Lightweight, compact construction makes the Zephyr a shoulder-weight hoist, portable to practically any location in the plant, easy to carry up a ladder, able to operate in tight corners.

EASY DISMANTLING Making periodic inspections, or replacing chains or parts, requires only a small wrench and screwdriver.

GEAR TRAIN Center planetary system using modified involute stub tooth form. Gear teeth are cut from solid alloy steel blanks and heat treated.

INTERNAL GEAR Nickel-chrome-molybdenum alloy steel, machine-cut teeth. Internal gear is heat treated and welded to frame.

GEARS AND PINIONS Nickel-chrome-molybdenum alloy steel, machine-cut teeth, heat treated, and mounted on heavy duty roller bearings.

GEAR AND PINION SHAFTS Rigidly mounted alloy steel, surface-hardened and ground.

PINION CAGE Splined to the steel load wheel shaft.

DRIVING SPINDLE Nickel-chrome-molybdenum alloy steel, with machine-cut teeth. Operates on heavy duty bearings.

LOAD WHEEL Heat treated cast steel with spline fit to load shaft. Chain pockets are accurately formed, and load wheel can be reversed when new chain is installed to effect double life.

CHAIN STRIPPER Ductile Iron.

LOAD BRAKE

Positive action.
Weston type with uniform composition lining and quiet-action forged alloy pawl.

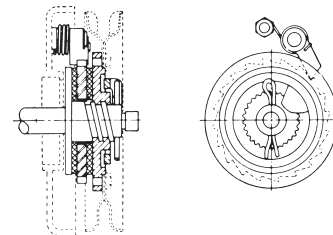

LOAD CHAIN GUIDE Completely shrouds load sheave, guides chain into load wheel and efficiently shields these parts from entry of foreign objects.

LOAD CHAIN Steel, with accurately formed links to fit pockets of load wheel. Heat treated for high tensile strength and hardness.

LOAD CHAIN GUIDE Designed to eliminate fouling, and to permit angular pull on the hand chain.

TOP HOOK ASSEMBLY Permits hoist to rock and swivel under load. Alloy crosshead rocks in rolled steel straps welded to frame. Alloy hook is heat treated. Drop-forged alloy steel hook will open before fracturing.

BOTTOM HOOK ASSEMBLY

Consists of forged alloy steel hook operating on thrust bearing with full swiveling action.

