

LPU LOW PLATFORM COIL UPENDER

PRODUCT FEATURES:

- Lower platform design offers easier access by operator.
- Fast and convenient way to upend coils to 90°.
- Requires less platform height.
- Magnetic starter with 115 volt pendant control.
- Double acting hydraulic cylinders.
- Relief valve prevents over-capacity rotation.
- Stop limit switches at each end of rotation.

PRODUCT OPTIONS:

- Larger platforms available.
- Unequal platform sizes available.
- V-Block, either standard or urethane faced.
- 180° horizontal rotation, which permits loading and unloading from same side.

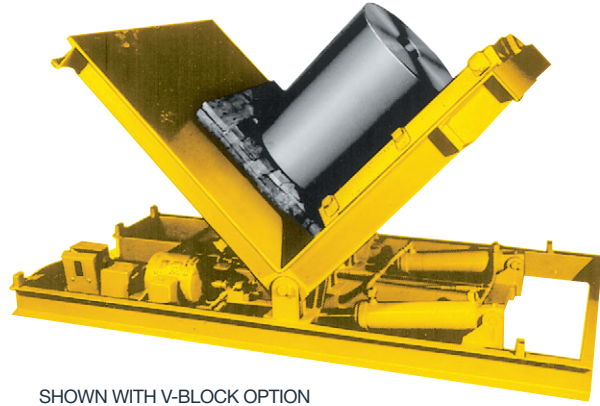

SHOWN WITH V-BLOCK OPTION

NOTE: If load is not a coil, specify center of gravity of load being rotated.

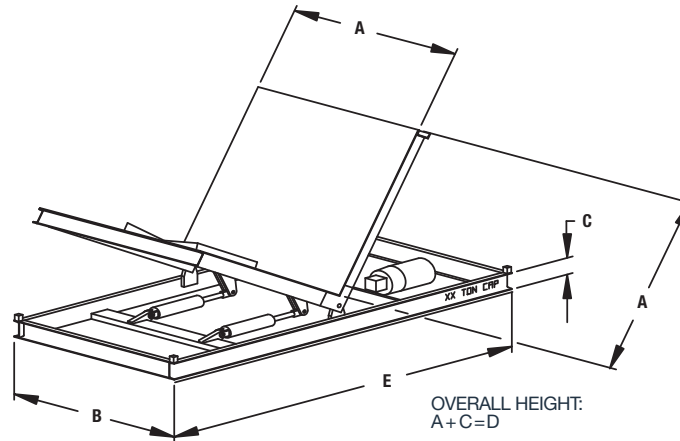

SPECIFICATIONS

Model Number	Capacity (tons)	Dimensions (inches)					Weight (lbs.)
		A	B	C	D	E	
LPU100036	1/2	36	36	8-1/4	44-1/4	78	1500
LPU136	1	36	36	9-1/4	45-1/4	78	1600
LPU1536	1-1/2	36	36	10-1/4	46-1/4	78	1800
LPU236	2	36	36	12-1/4	48-1/4	78	2000
LPU2542	2-1/2	42	42	13-1/4	55-1/4	90	2200
LPU342	3	42	42	14-1/4	56-1/4	90	2300
LPU3542	3-1/2	42	42	15-1/4	57-1/4	90	2400
LPU442	4	42	42	17-3/8	59-3/8	90	2600
LPU4548	4-1/2	48	48	18-3/8	66-3/8	102	2800
LPU548	5	48	48	19-3/8	67-3/8	102	3000
LPU648	6	48	48	20-3/8	68-3/8	102	3600
LPU7548	7-1/2	48	48	20-3/8	68-3/8	102	5000

Pallets must not extend over platform sides. Other sizes available, consult factory.