

## Lift-A-Lift® Forklift Service Lift

**Fast, Safe and Easy Maintenance for  
Forklifts • Industrial Vehicles • Light Trucks**

Tilt-or-Lift, Inc., the leading designer of specialty lifts since 1973, has raised the art of forklift maintenance to new heights with the *Lift-A-Lift*® forklift service lift.

The *Lift-A-Lift* service lift, model V-13-A, is designed to allow complete access to the underside parts of forklifts, industrial trucks and motor vehicles for lubrication, repair or part replacement. Just drive the vehicle onto the 16 inch wide runways. The self-leveling lift raises the vehicle up to 71 inches so all maintenance can be performed while standing.

### High Marks for Safety and Versatility

The *Lift-A-Lift* service lift complies with applicable ANSI and OSHA requirements. Automatic safety pawls are incorporated in the design to prevent accidents in the event of hydraulic failure.

The *Lift-A-Lift* service lift is portable and has removable runway panels and floor beam for easier access. Standard 16 inch wide runways are factory set at 52 to 68 inches (outside dimension) to accommodate a wide range of vehicles. The lift is available in 13,000 lbs. GVW capacity. A variety of popular options is available to enhance its utility. All lifts are shipped assembled and factory tested and carry a full one-year warranty.

The *Lift-A-Lift* service lift; one of the fine family of forklift service lifts available from Tilt-or-Lift, Inc., the lift specialists. There are no finer lifts available — anywhere.

**“We stand under our products.”**

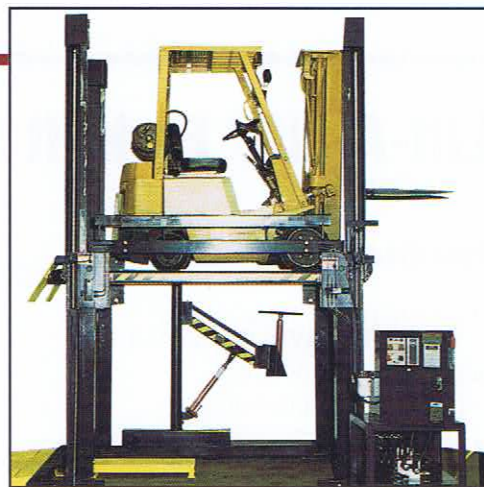

**TILT OR LIFT**  
INCORPORATED  
Manufacturers of  
Fork Lift Maintenance Lifts

**TAYLOR**  
MATERIAL HANDLING & CONVEYOR  
Phone: 419-867-3560  
[www.taylormhc.com](http://www.taylormhc.com)

# Lift-A-Lift® Forklift Service Lift

## Specifications

- Capacity: GVW (Model V-13AF8) 13,000 lbs.
- Entry width 52" to 68" (Specify 4" increments)
- Minimum ceiling height: 12' 7"
- Ramp: length 4'
- Max runway height: 71"
- Safety locks: automatic
- Motor: 3 hp  
Power: 3-phase only
- Shipping weight: 6200 lbs. (approx.)
- 16" wide runways x 8' long
- 20" to 36" inside working width (Specify 4" increments)

All units are subject to change and modifications

**Note:** Dimensions may change without notice.

## Features

- Portable, hydraulic lift
- Auto safety locks
- Auto self-leveling system
- Removable runway panels
- Lockable control panels
- Shipped assembled and factory tested

## Options

- Hydraulic motor/transmission jack
- Ramp - 10' long
- Pallet jack combo kit - center ramp & 2 side rails
- Wheel-freeing device
- Three-wheel platform

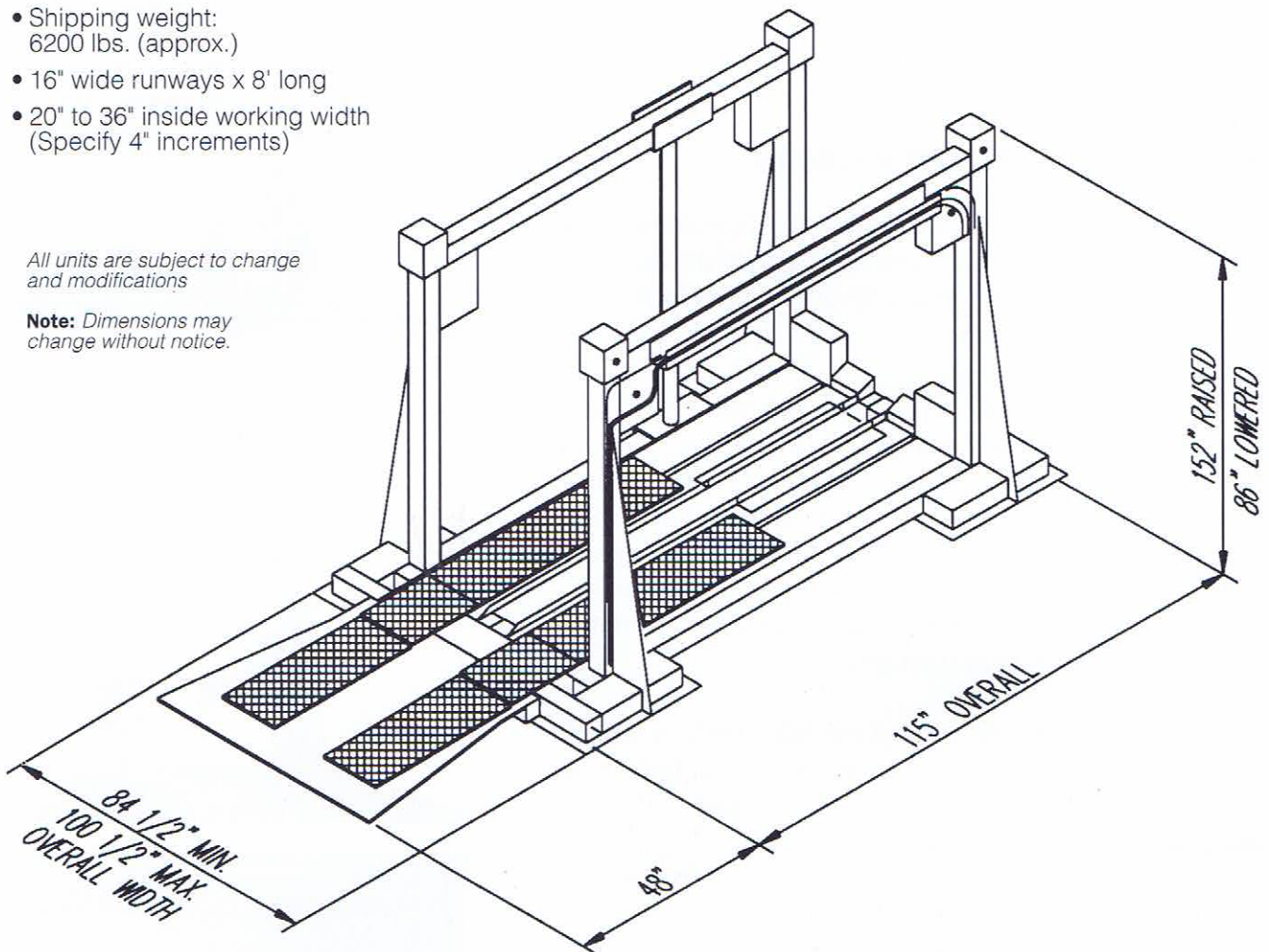

**LIFT**  
**OR**  
**LIFT**  
INCORPORATED  
Manufacturers of  
Fork Lift Maintenance Lifts

**TAYLOR**  
MATERIAL HANDLING & CONVEYOR  
Phone: 419-867-3560  
www.taylormhc.com