

Automatic Operation & Two Stations Streamline Your Wrapping Operation

The Flex CTS was designed for users who need to boost pallet wrapping efficiency by keeping forklift operators busy and productive. Automatic operation combined with a gravity conveyor to hold wrap loads allows for a steady flow of loads without requiring forklift drivers to exit the vehicle.

Once a pallet load is wrapped, the powered turntable moves the load to a gravity conveyor for pick up. This eliminates the need for forklift drivers to double-handle wrapped loads to make room on the turntable.

After placing the load on the powered turntable the forklift driver starts the wrap cycle via an included lanyard or an optional remote control device. Your forklift operators stay in the vehicle for maximum productivity.

The gravity conveyor section, which acts as a buffer zone to hold wrapped loads, can be optionally extended to hold two wrapped loads versus one on the standard conveyor section. For those applications which require weighing of each load, adding an optional load cell package gives operators an accurate weight of each load.

Performance Features

- Adjustable 15 RPM turntable rotation
- 4,000 lbs load capacity
- Low-maintenance AC motors with VFD
- 7" HD color touch panel
- IntelleVue™ operating system
- Precision ring bearing turntable support
- Robust turntable chain drive
- 260% powered prestretch
- Fast & safe stretch film loading
- Automatic load height sensing
- Belt carriage lift with "drop lock"

Automatic Sequencing:

- 1) Forklift driver places load on turntable
- 2) Driver starts cycle remotely
- 3) Load is wrapped, film tail is cut
- 4) Film tail wiped to load as load exits to gravity
- 5) Turntable is now clear & ready for new load



The Flex CTS increases your pallet wrapping efficiency by eliminating the bottle neck of a single turntable wrapper.

SPECIFICATIONS

Max. Load Size	48" W x 48" L x 72" H
Min. Load Size	36" W x 36" L x 15" H
Max. Load Weight	4,000 lbs.
Min Load Weight	Approx. 100 lbs. depending on load type
Stretch Film	20" Wide, up to 110 Gauge (30" optional)
Min. Load Height	Approx. 24"
Rotation Speed	Adjustable up to 15 RPM
Film Tension	Adjustable on HMI
Powered Prestretch rate	250% Standard (higher/lower optional)
Required Voltage	115Volt 20Amp Service
Motors	High Efficiency AC with VFD drives
Required Air	80 PSI @ 3 CFM
Stretch Film	20" roll size up to 110 gauge
Warranty	4 Year (Lifetime on InstaThread rollers)
HMI Controller	IntelleVue with 7" HD color touch panel
HMI Language	English / Spanish
HMI Connectivity	USB & Ethernet for remote diagnostics
Control Box	NEMA 12 Rated
Turntable Support	Precision ring bearing
Construction	Structural steel tube base frame/steel mast

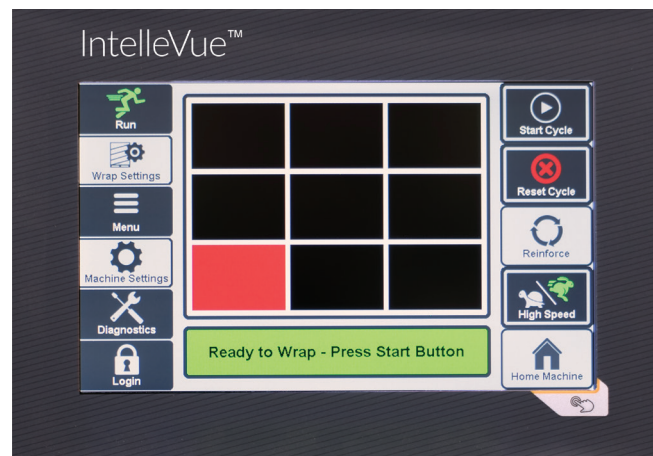

The new IntelleVue control package is Orion's most powerful and intuitive HMI. An icon based menu makes programming the CTS as easy as using a smart phone. Three levels of security protect unauthorized changes, while a convenient USB port allows for fast and convenient software 'updates. Other features include onboard instructions and troubleshooting, PM notifications, remote connectivity, and 10 wrap recipes.

DIMENSIONS

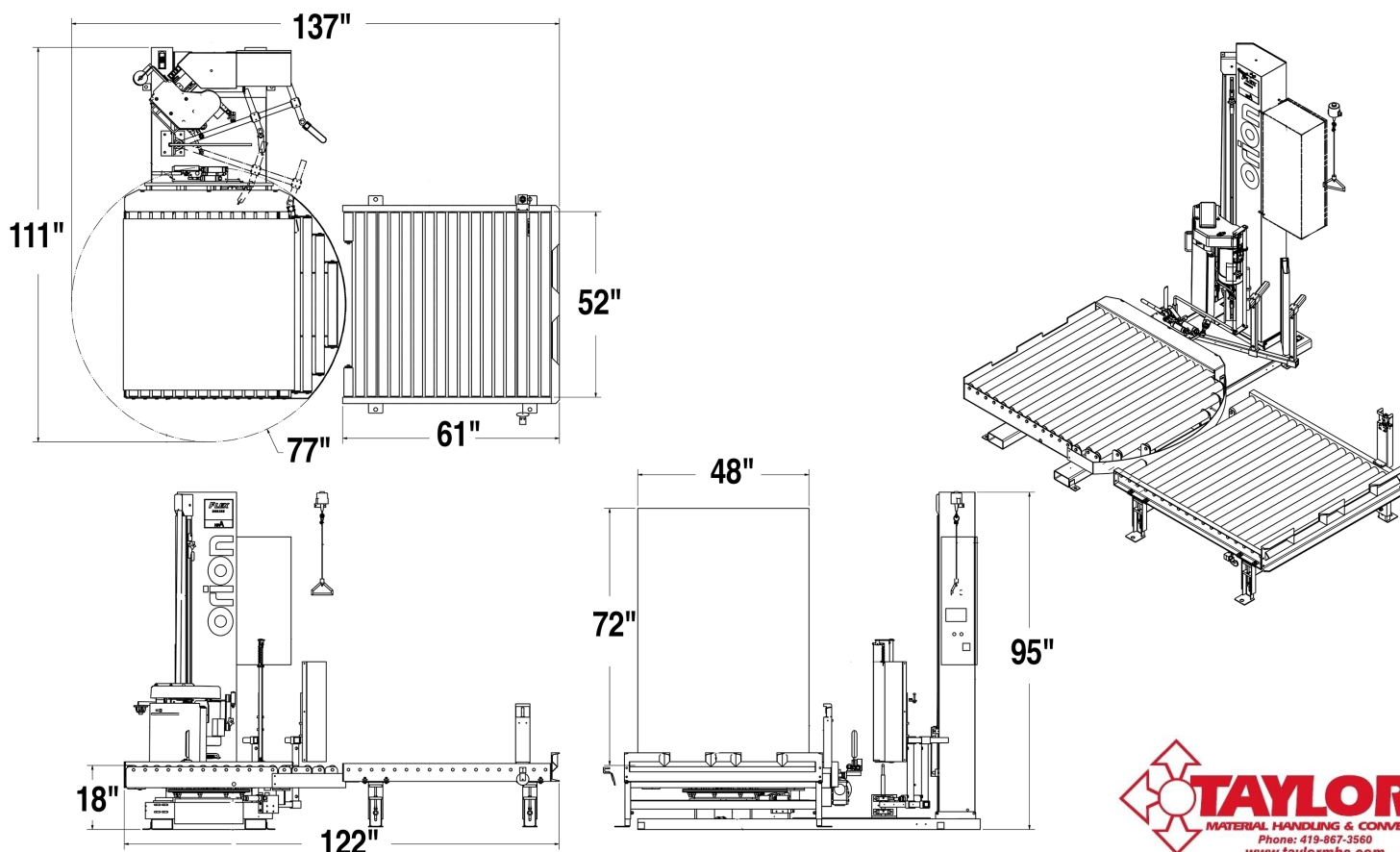

All dimensions approximate. Orion reserves the right to change specifications without notice

